

# CIS 3250

## Advanced Network Architecture

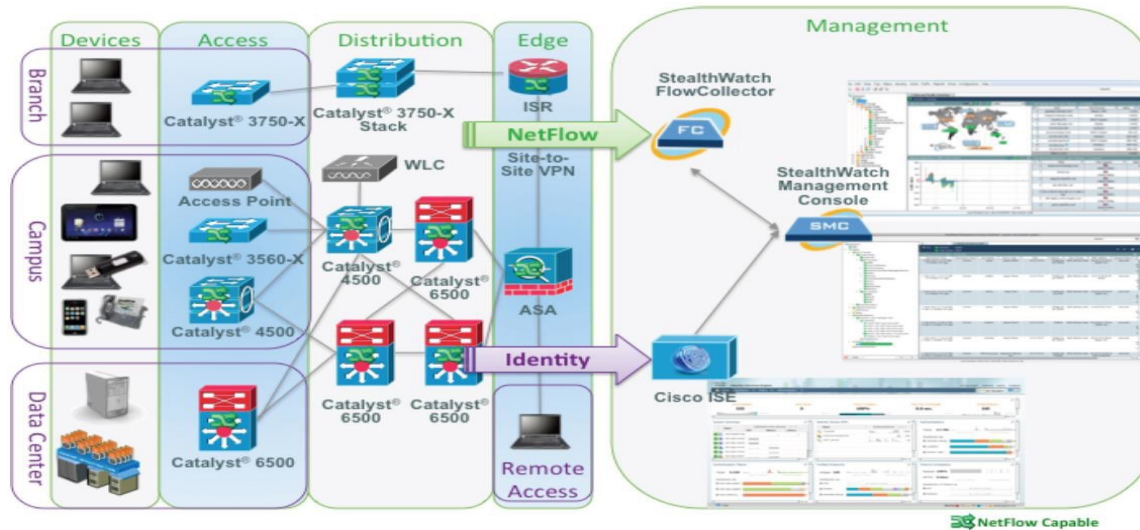

# Cisco Networking Academy

The screenshot shows the Cisco Networking Academy website. At the top, the Cisco logo and 'Cisco Networking Academy' are on the left, and 'Mind Wide Open' is on the right. Below the header, there are navigation links for 'Courses', 'Careers', and 'About Us'. A search bar and 'English' and 'Log In' options are also present. The main content area features a dark blue background with the text 'Empowering all people with career possibilities'. Below this, it states: 'Cisco Networking Academy transforms the lives of learners, educators and communities through the power of technology, education and career opportunities. Available to anyone, anywhere. We're currently providing assistance for you to teach and learn remotely.' A yellow button labeled 'Explore remote tools and tips' is visible. To the right of the text is a photograph of three students (two women and one man) looking at a tablet. Below the main content, there is a paragraph: 'An incredible opportunity is waiting for you. Technology is changing the world by connecting billions of devices and improving how we live, work, play and treat our planet. No industry is immune. Are you ready to change your life, and possibly make the world a better place?'. At the bottom, there are seven circular icons representing different areas: Networking, OS & IT, Programming, Internet of Things, Infrastructure Automation, Cybersecurity, and Packet Tracer.

- Everyone can access the [Cisco Networking Academy](#) or [Skills for All](#) website. It provides us with the ability to use Packet Tracer for our labs. You will also have access to the *Introduction to Packet Tracer* course if you want to learn more.

# CIS-3250

- Lecture

- VTSU Zoom
- **Monday/Wednesday 3:30–4:45 pm**
- Lectures, Simulations
- Some demonstrations
- Listen to the lecture from anywhere
- Attendance at lectures is not mandatory but suggested
- Lectures are recorded and can be reviewed later

- Lab

- Friday, 3:00–5:00 pm, CON-106 (Randolph) and Zoom

# CIS-3250 Description

- This course teaches students how to implement, monitor, deploy, and maintain a network in a *converged* enterprise environment.

Students will learn how to plan, configure, and verify the implementation of complex enterprise routing and switching solutions. The course also covers the secure integration of VLANs, WLANs, voice, and video into networks.

Comprehensive labs emphasize hands-on learning and practice to reinforce the skills learned in class.

# What will you learn?

- Fun Stuff!
  - Routing protocols (beyond CIS-3210).
  - Managing high-availability networks
  - Managing wireless networks, including security and privacy constraints.
  - Managing voice networks.
  - VLANs, trunks, and VTP (VLAN Trunking Protocol and DTP (Dynamic Trunking Protocol)).
  - Implementing high-performance networks.
  - Understanding port aggregation, Ether channel, spanning tree protocol, and CIDR.

# *Networks - Review*

# Reasons for Layering

- Advantages
  - Simplifies the networking model
  - Enables programmers to specialize in a particular level or layer
  - Provides design modularity
  - Encourages interoperability
  - Allows networking vendors to standardized interfaces

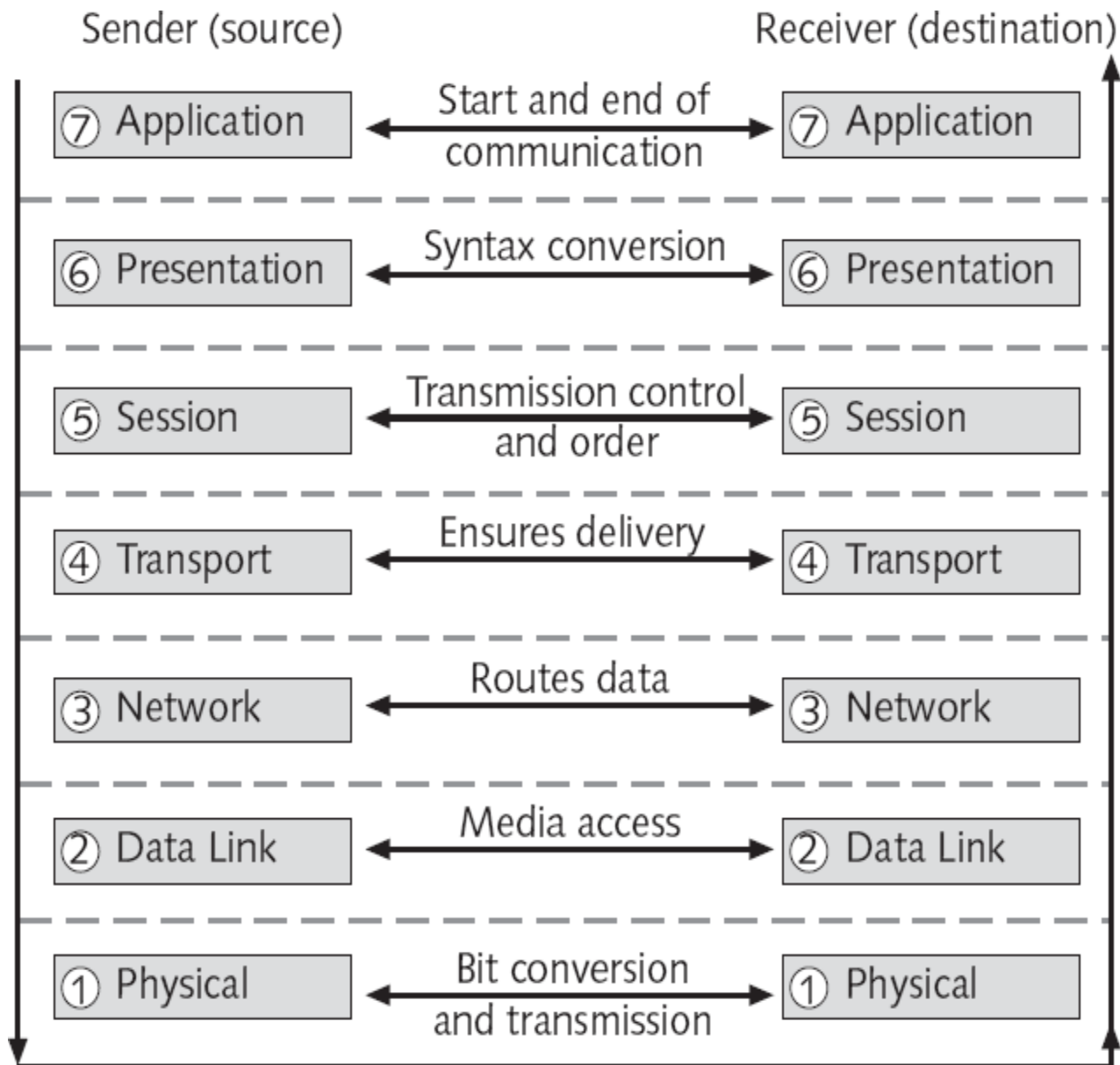
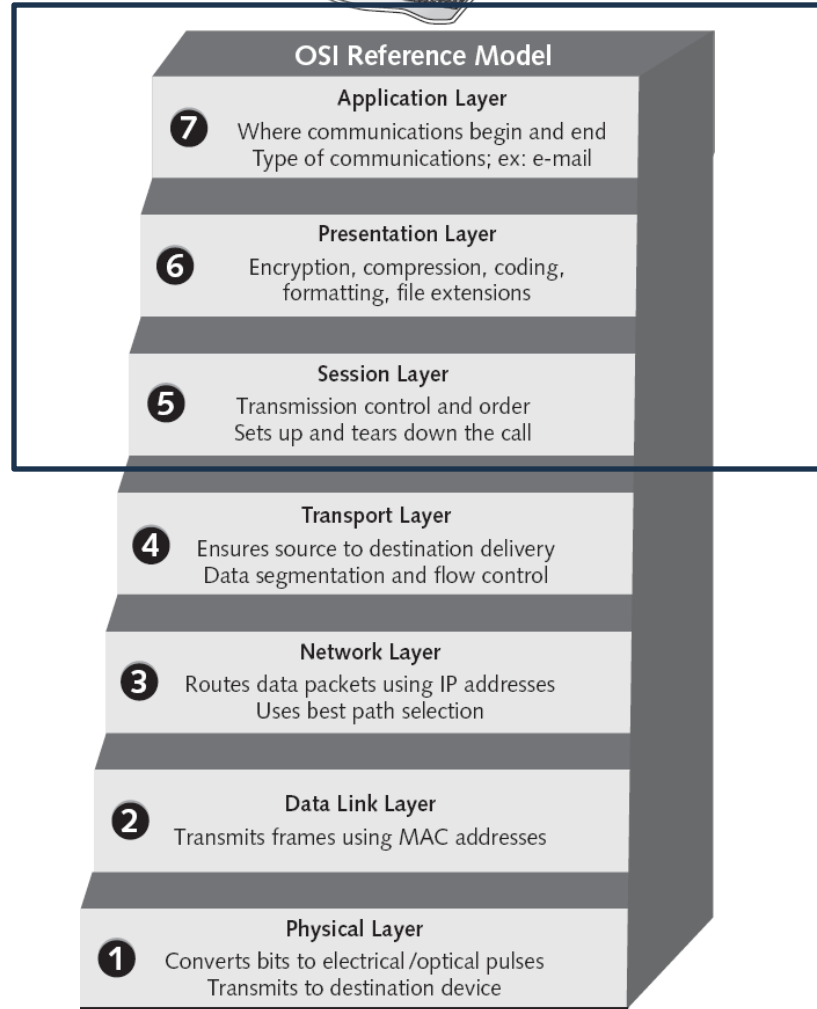
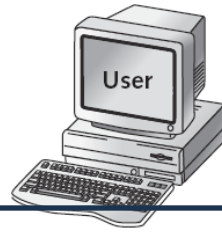

**Figure 1-1** OSI reference model



# Layer Functions

- The OSI model was developed as an industry standard...
  - ...for companies to use when developing network hardware and software to ensure complete compatibility
- Each layer in the OSI model performs a specific function in the transmission process
- Most modern networks do not implement the OSI model precisely as it is defined



Application layer

Layer Functions

# Layer Functions (continued)

- **Physical (Layer 1) responsibilities:**
  - Defines the physical characteristics of the network hardware, including cable and connectors
  - Represents binary digits as voltages (encoding)
  - Transmits signals on the wire

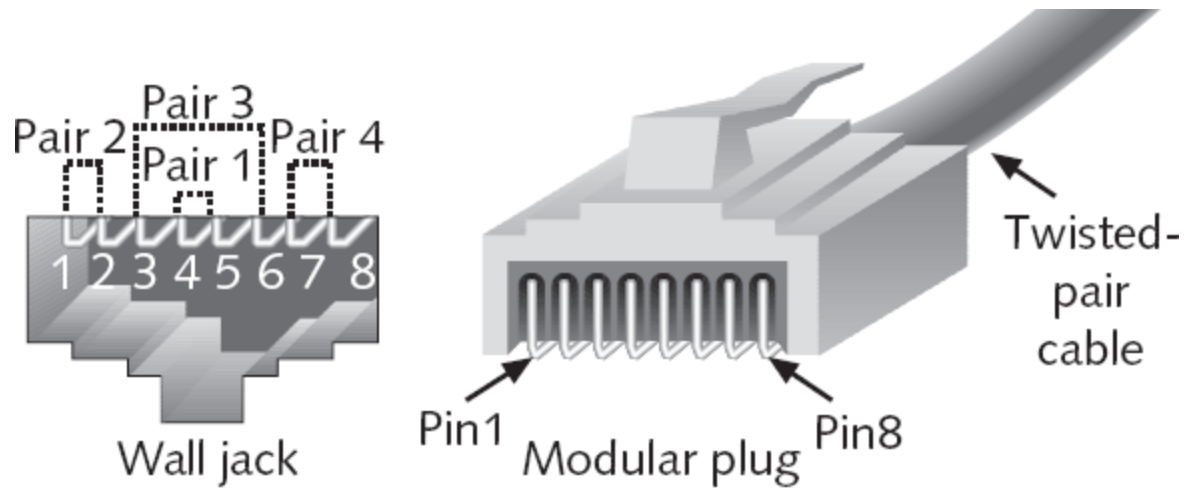

Color code  
option 1

- 1 white/orange
- 2 orange
- 3 white/green
- 4 blue
- 5 white/blue
- 6 green
- 7 white/brown
- 8 brown

Color code  
option 2

- 1 black
- 2 yellow
- 3 blue
- 4 red
- 5 green
- 6 orange
- 7 brown
- 8 slate

568B twisted-pair wiring scheme

# Layer Functions (continued)

- **Data Link (Layer 2) responsibilities:**
  - Network interface functions, including the identification of the source and destination nodes via their physical addresses (Media Access Control addresses)
  - Definition of how data is packaged for transport in smaller units known as frames
  - Error notification
- The Data Link sublayers:
  - **Logical Link Control (LLC) layer**
  - **Media Access Control (MAC) layer**

# Layer Functions (continued)

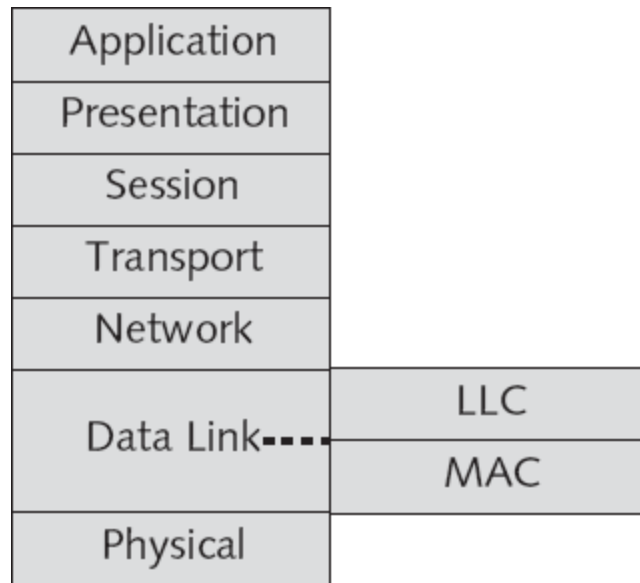

Data Link layer subdivision

# Layer Functions (continued)

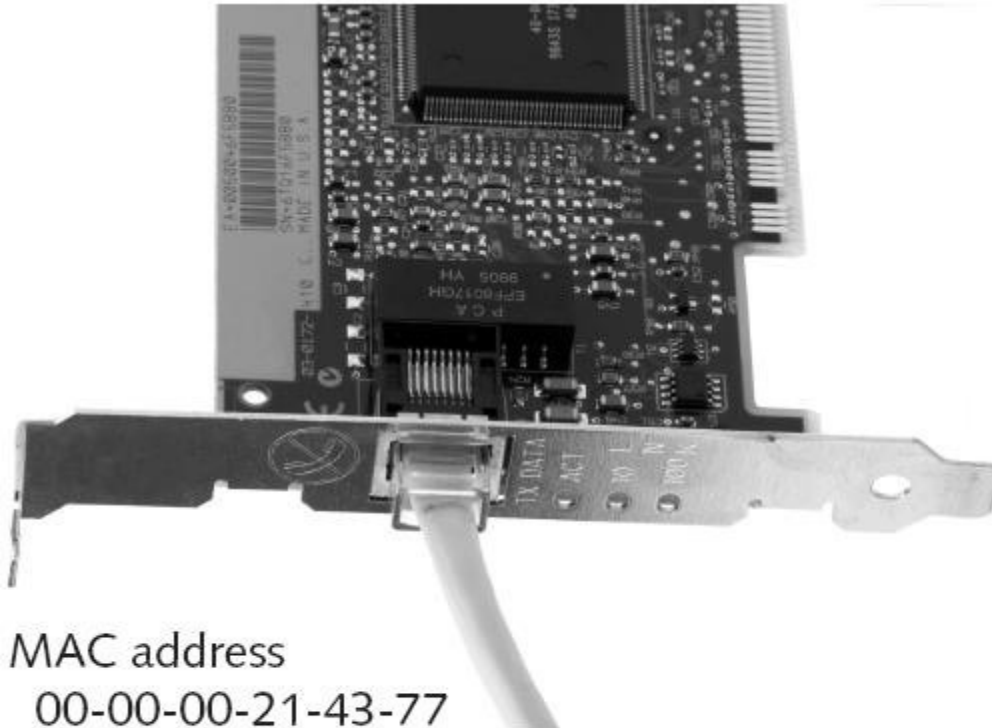

MAC address

00-00-00-21-43-77

**re 1-5** Network adapter

(Image © Timothy Geiss, 2008. Used under license from Shutterstock.com.)

# Layer Functions (continued)

- **Network (Layer 3) functions:**
  - Software/logical addressing for data **packets**, such as IP, IPX, and AppleTalk
  - Data routing and connectivity
  - Best path selection
- Network layer protocols allow computers to route packets to remote networks using a **logical address**.



# Layer Functions (continued)

- **Transport (Layer 4)** responsibilities:
  - End-to-end, error-free transmission and delivery between the ultimate sender and ultimate receiver
  - Flow control
  - Data segmentation into maximum transmission unit (MTU) size
  - Messaging service for the Session layer
- Protocols that reside at the Transport layer can be **connection-oriented** or **connectionless**.
- Data sent by a connectionless transport is called a **datagram**.

# Layer Functions (continued)

- **Session (Layer 5) services:**
  - Control for data exchange (full or half duplex)
  - Clocking or timing
  - Failure recovery
  - Initial link setup and link termination when communications are complete
- The Session layer allows the transfer of a large set of data across the network
- Examples of Session layer protocols include NetBIOS, **SQL**, **RPC**, and **X-Windows**

# Layer Functions (continued)

- **Presentation (Layer 6) responsibilities:**
  - Data translation
  - Data formatting
  - Data syntax restructuring
  - Data encryption
  - Data compression
- This layer also provides encryption services when data encryption is used in network communications.

# Layer Functions (continued)

- **Application (Layer 7) responsibilities:**
  - Initiating the request for network services
  - Providing network services to applications such as e-mail and Web browsers
  - This layer is concerned with user interaction with the computer and the network
  - Contains many protocols and utilities, such as telnet, FTP, HTTP, DNS, SMTP, and SNMP

# Introduction to WANs

## WAN Devices

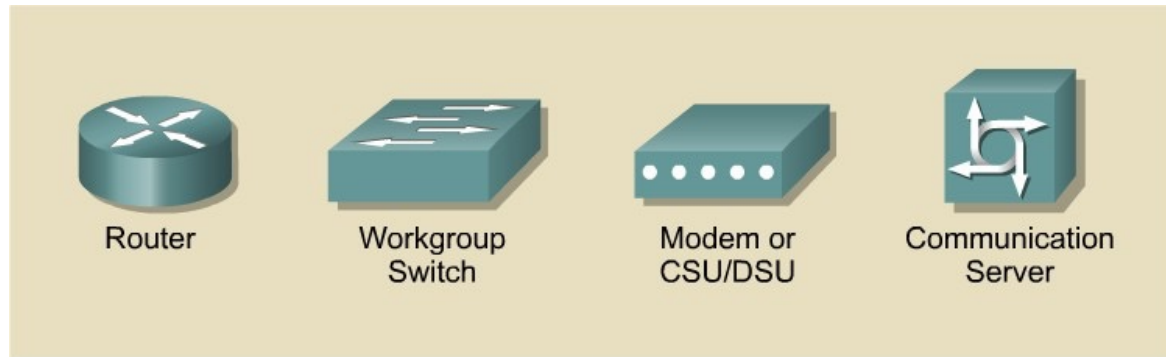

### WANs are designed to:

- Operate over a large geographic area
- Allow access over serial interfaces operating at lower speeds
- Provide full-time and part-time connectivity

- **Routers** offer services such as internetworking and WAN interface ports.
- **Switches** provide connectivity for voice, data, and video communication.
- **Modems** interface voice-grade services, channel service units/digital service units (CSU/DSUs) that interface T1/E1 services, and Terminal Adapters/Network Termination 1 (TA/NT1s) that interface Integrated Services Digital Network (ISDN) services.
- **Communication servers** concentrate on dial-in and dial-out user communication.

# Introduction to WANs

## WAN Services

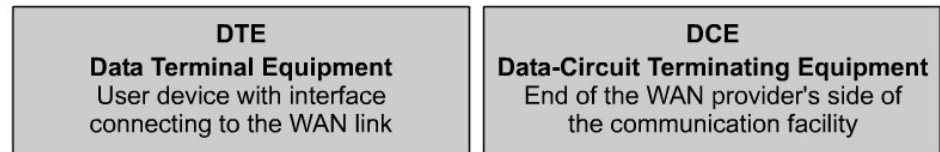
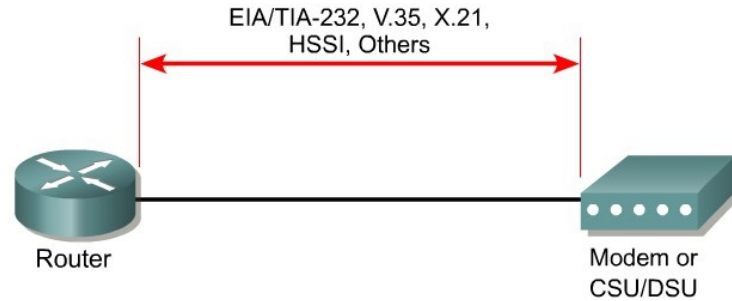

## Data Link Encapsulations

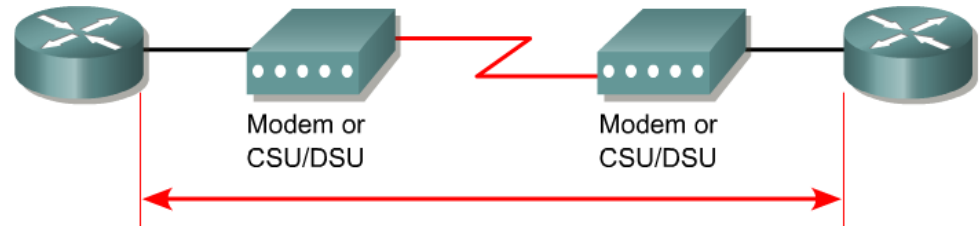

- HDLC – High-Level Data Link Control
- Frame Relay – Successor of X.25
- PPP – Point-to-Point Protocol
- ISDN – Integrated Service Digital Network (data link signal)

# Introduction to routers in a WAN

Routers connect and allow communication between two networks and determine the best path for data to travel through the connected networks.

## RAM:

- Stores routing tables
- Holds ARP cache
- Holds fast-switching cache
- Performs packet buffering (shared RAM)
- Maintains packet-hold queues
- Provides temporary memory for the configuration file of the router while the router is powered on
- Loses content when the router is powered down or restarted

## NVRAM:

- Provides storage for the startup configuration file
- Retains content when the router is powered down or restarted

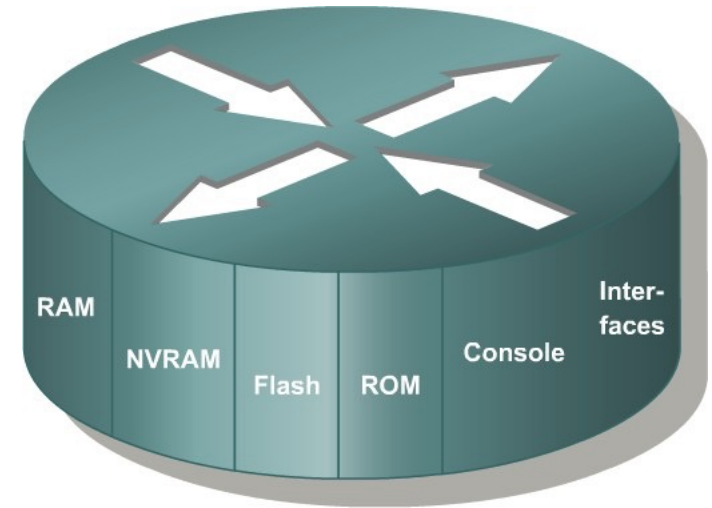

# Introduction to routers in a WAN

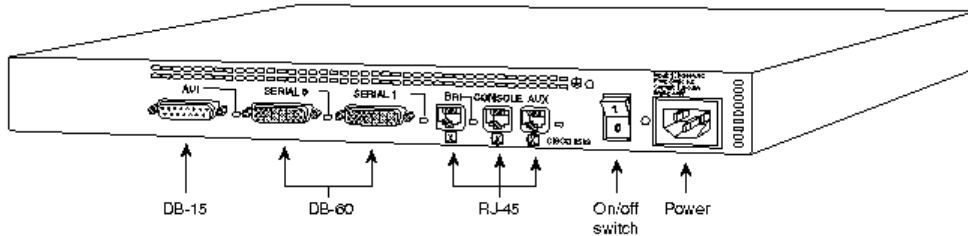

## Flash memory:

- Holds the operating system image (IOS)
- Allows software to be updated without removing and replacing chips on the processor
- Retains content when the router is powered down or restarted
- Can store multiple versions of IOS software
- It is an electronically erasable, programmable ROM (EEPROM).

## Read-only memory (ROM):

- Maintains instructions for power-on self-test (POST) diagnostics
- Stores bootstrap program and basic operating system software
- Requires replacing pluggable chips on the motherboard for software upgrades

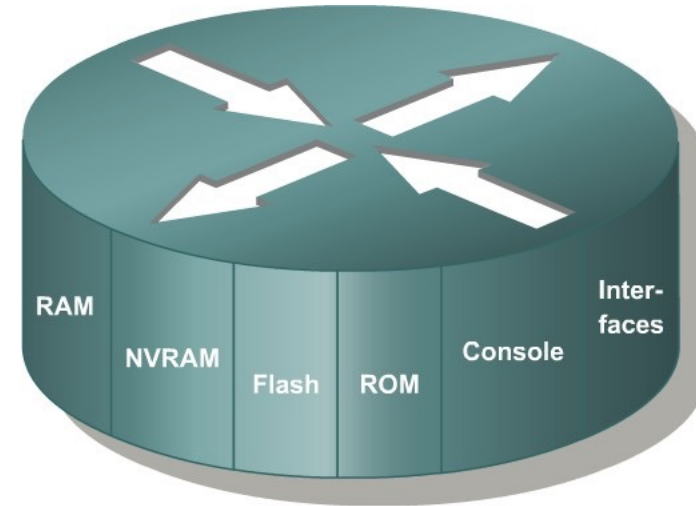



# Router LANs and WANs

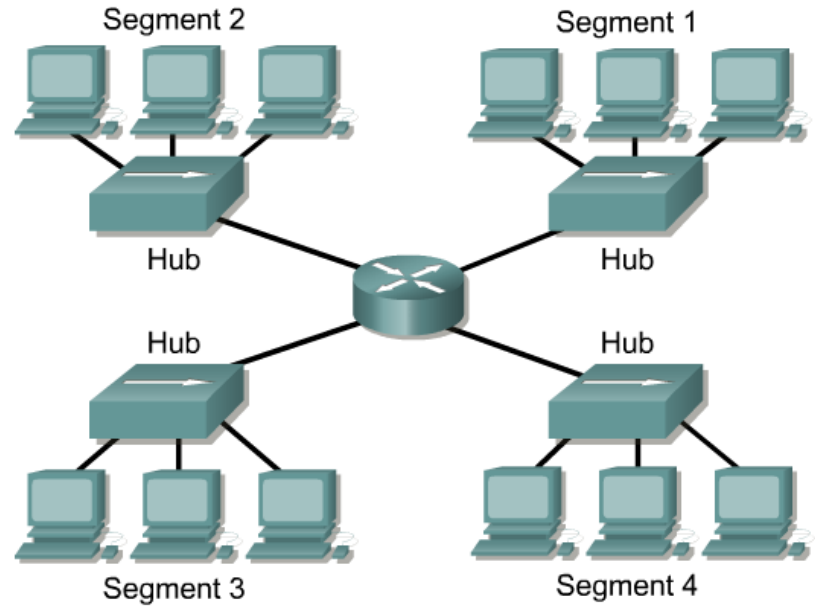

## Segmentation with Routers

- More manageable, greater functionality, multiple active paths
- Smaller collision domains
- Operates at Layer 3

- Smaller broadcast domains
- Connecting Layer 3 networks

# Router LANs and WANs

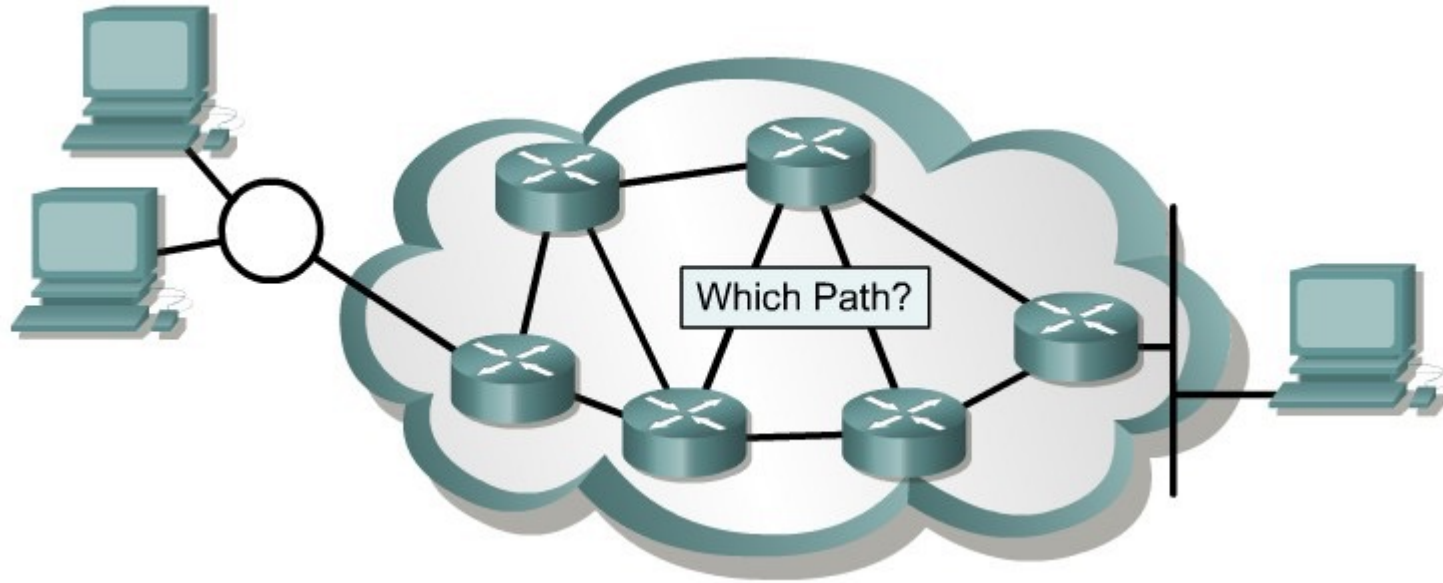

- Routers are the backbone devices of large intranets and of the Internet. They operate at Layer 3 of the OSI model, making decisions based on network addresses.
- The two main functions of a router are the selection of the best path and the switching of frames to the proper interface.
- Routers accomplish this by building routing tables and exchanging network information with other routers.

# Router role in a WAN

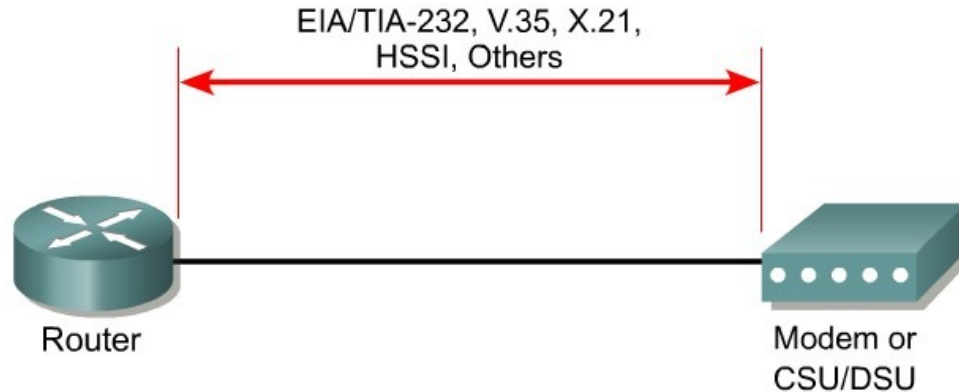

- The WAN physical layer describes the interface between the data terminal equipment (DTE) and the data circuit-terminating equipment (DCE).
- Generally, the DCE is the service provider, and the DTE is the attached device. In this model, the services offered to the DTE are made available through a modem or a CSU/DSU.

# Router role in a WAN

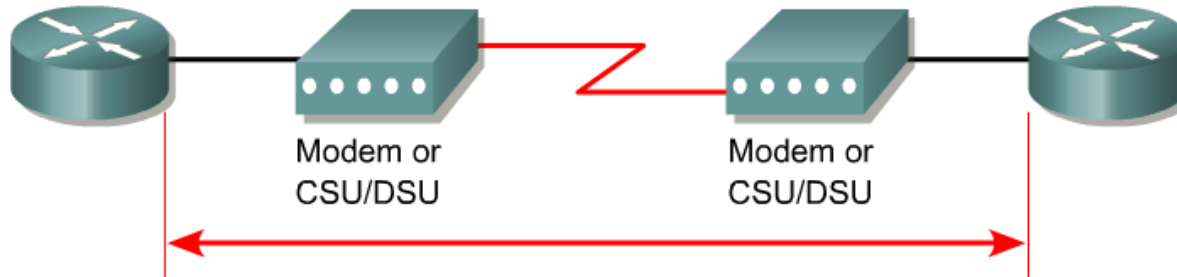

- HDLC – High-Level Data Link Control
- Frame Relay – Successor of X.25
- PPP – Point-to-Point Protocol
- ISDN – Integrated Service Digital Network (data link signal)

- Therefore, a router's primary WAN role is not routing but providing connections to and between the various WAN physical and data-link standards.
- For example, a router may have an ISDN interface using PPP encapsulation and a serial interface terminating a T1 line using Frame Relay encapsulation.

# Approach to hands-on labs

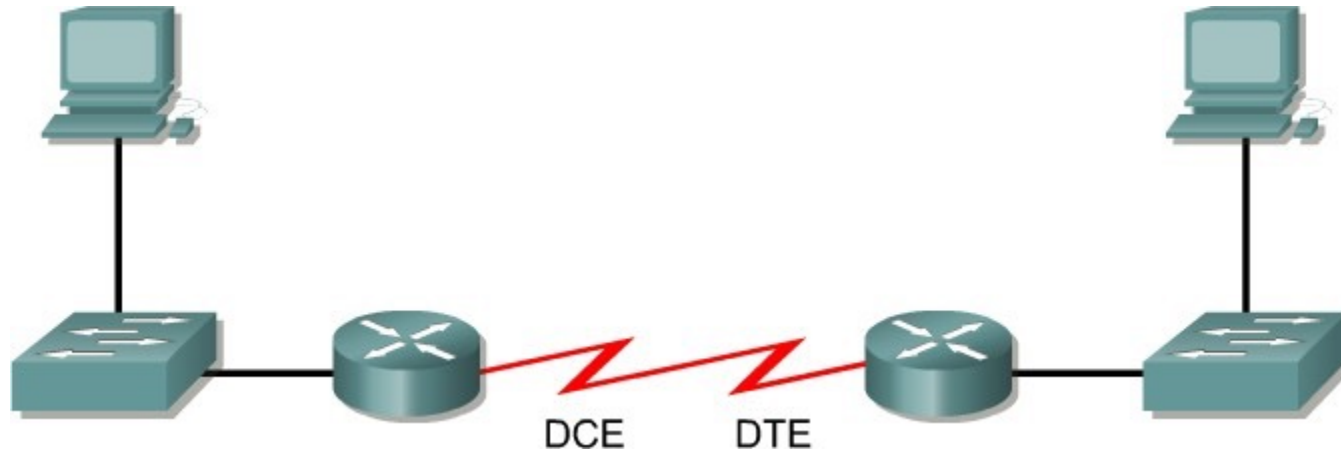

- In the lab, devices that make up the WAN cloud are simulated by the connection between the back-to-back DTE-DCE cables.
- One of the routers will provide the clock rate.

# Router internal components

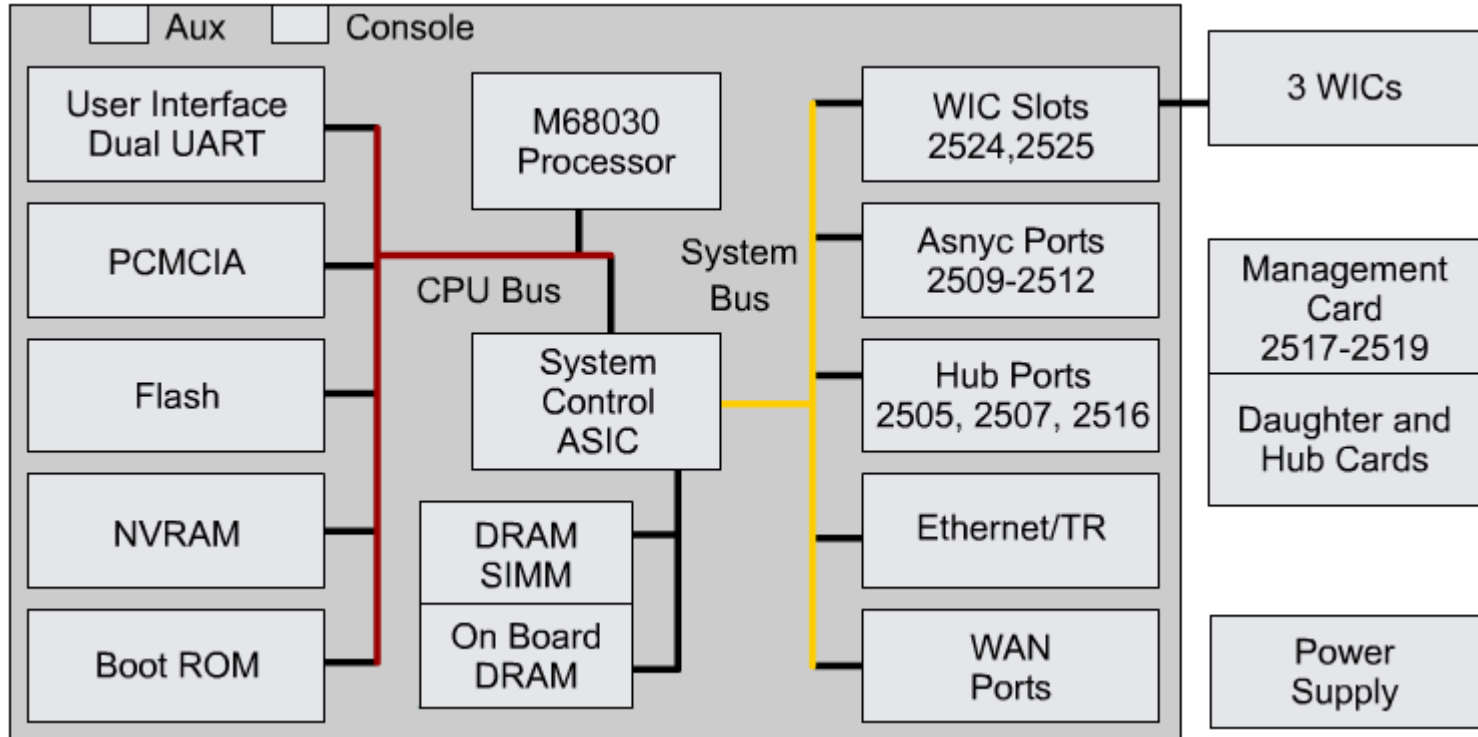

- CPU
- RAM
- Flash
- NVRAM

# Router physical characteristics

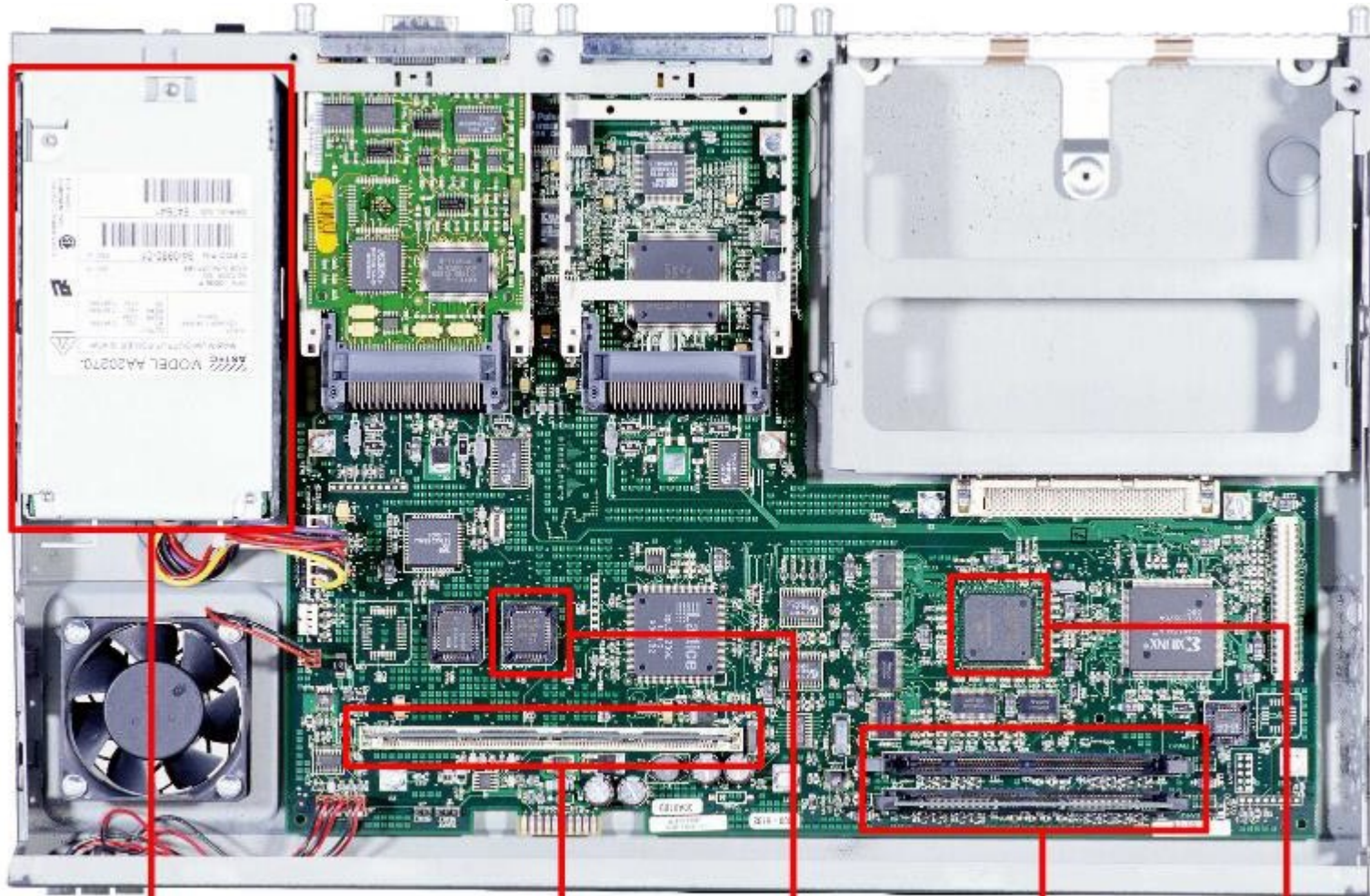

Power Supply

Flash SIMM

Boot ROM

RAM DIMMs

CPU

# Router external connections

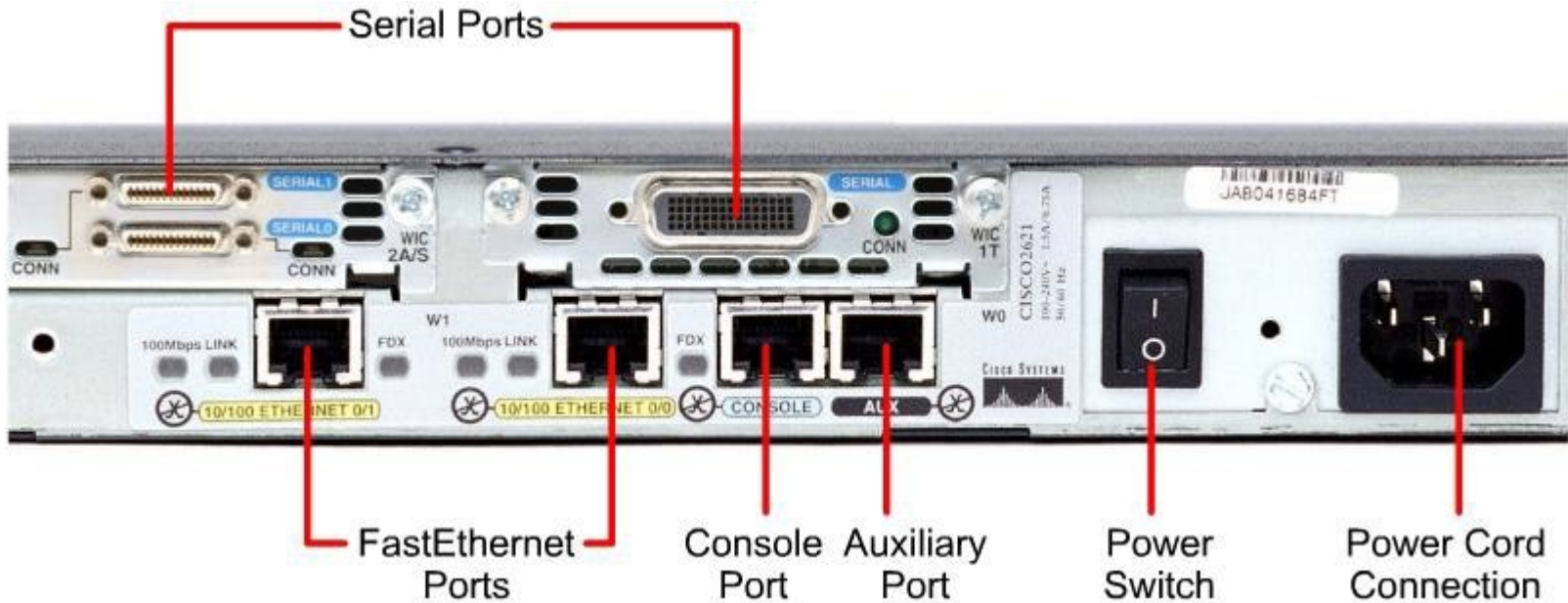



# Management port connections

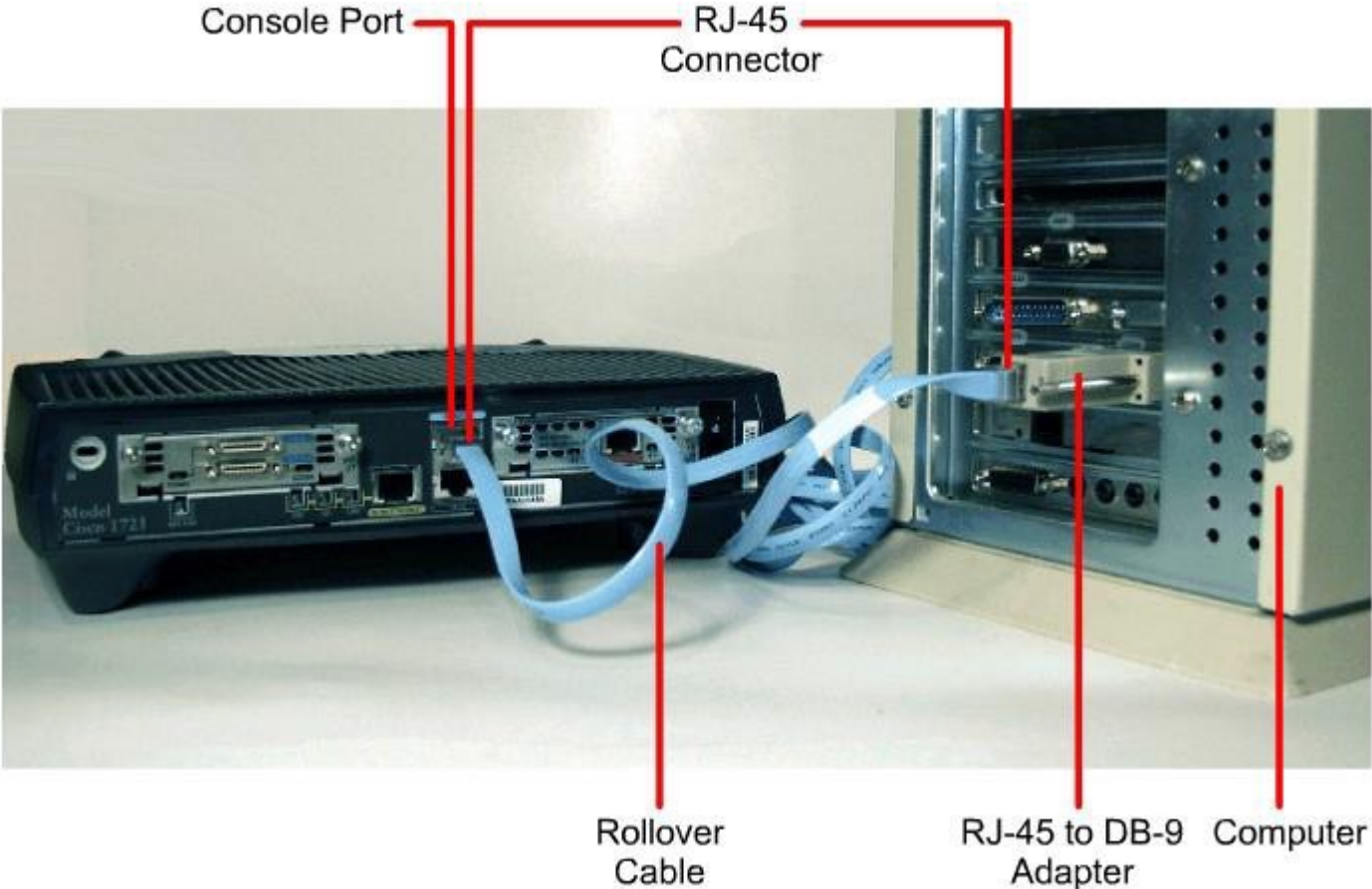

# Management port connections

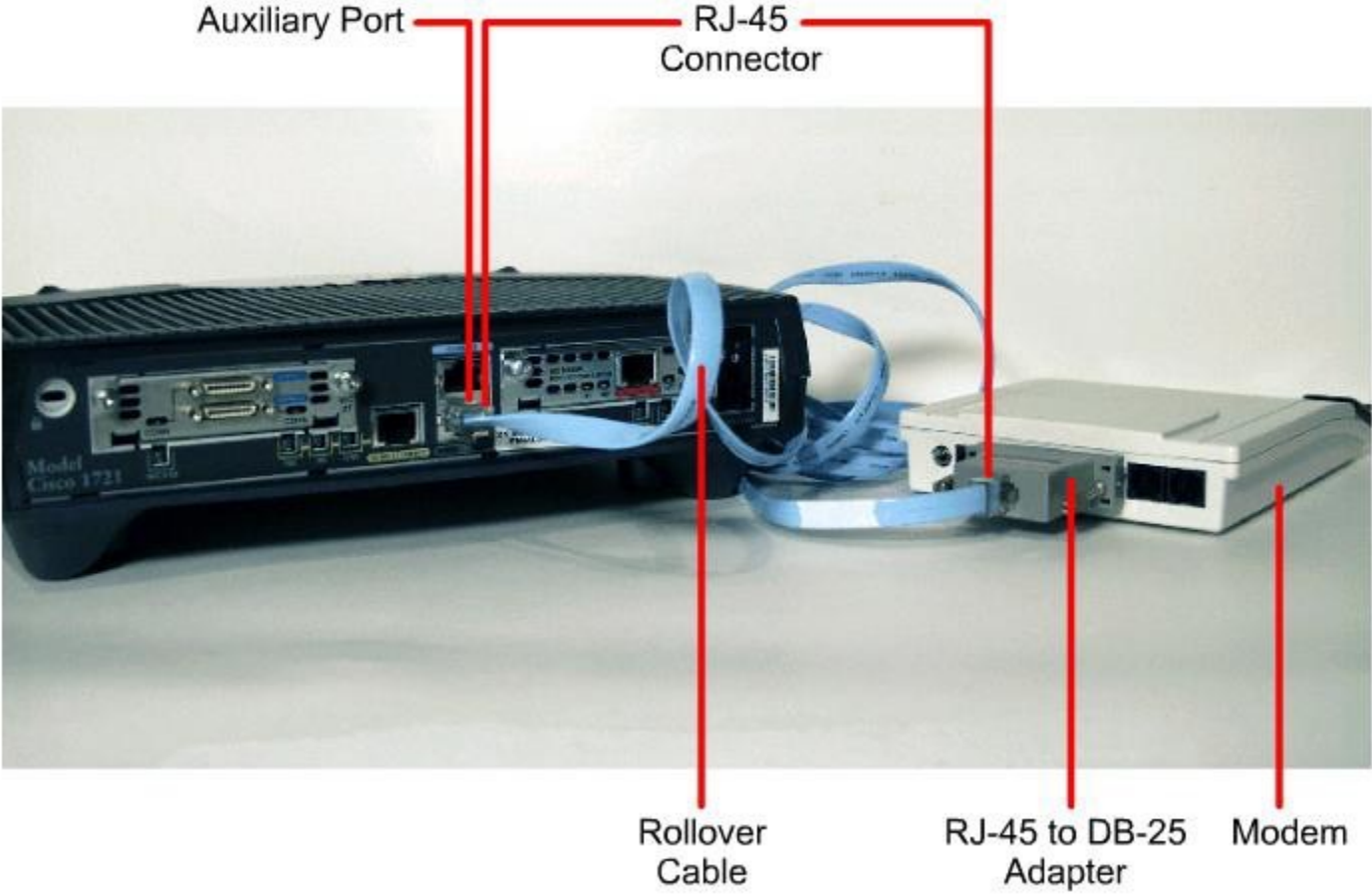

# Connecting console interfaces

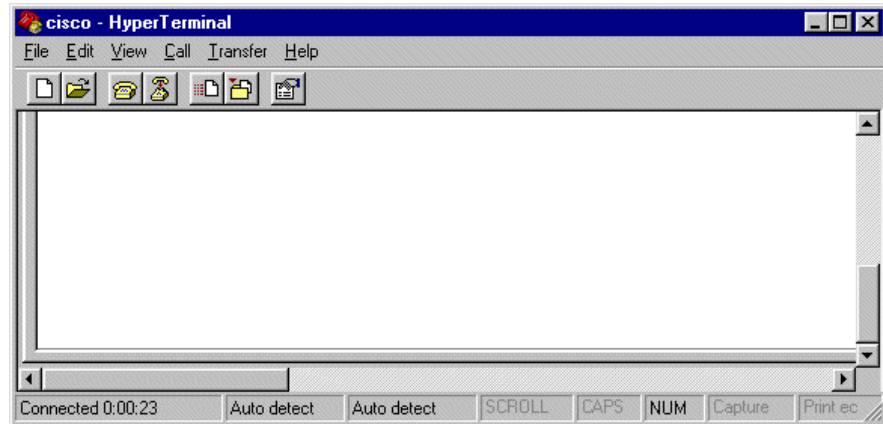
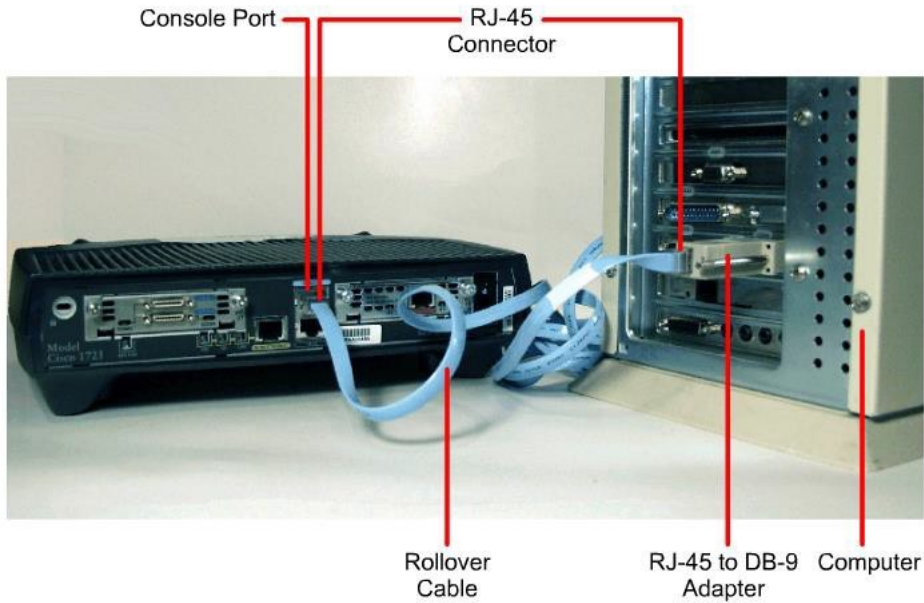

# Connecting console interfaces

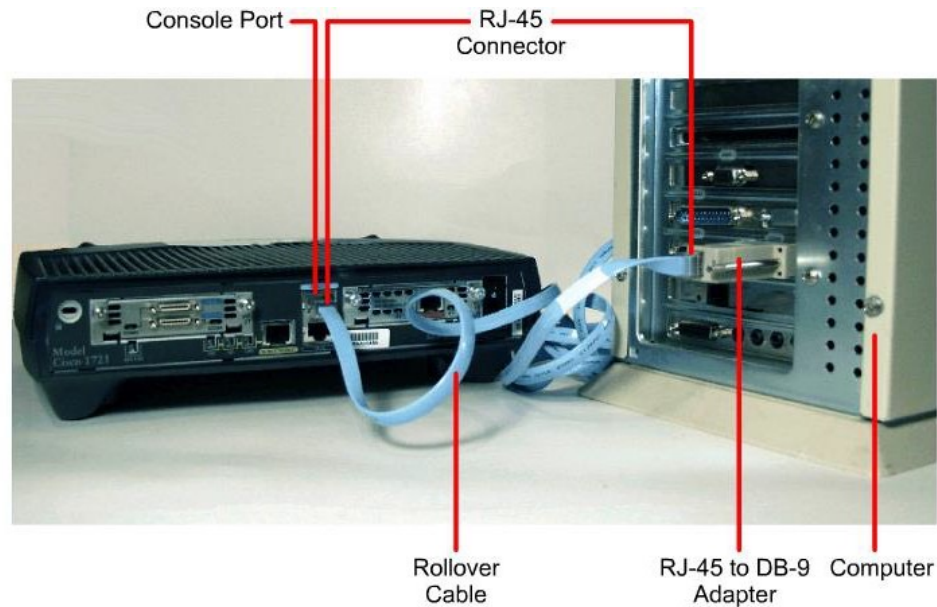

PuTTY, Teraterm, Gtterm, minicom

# Connecting LAN interfaces

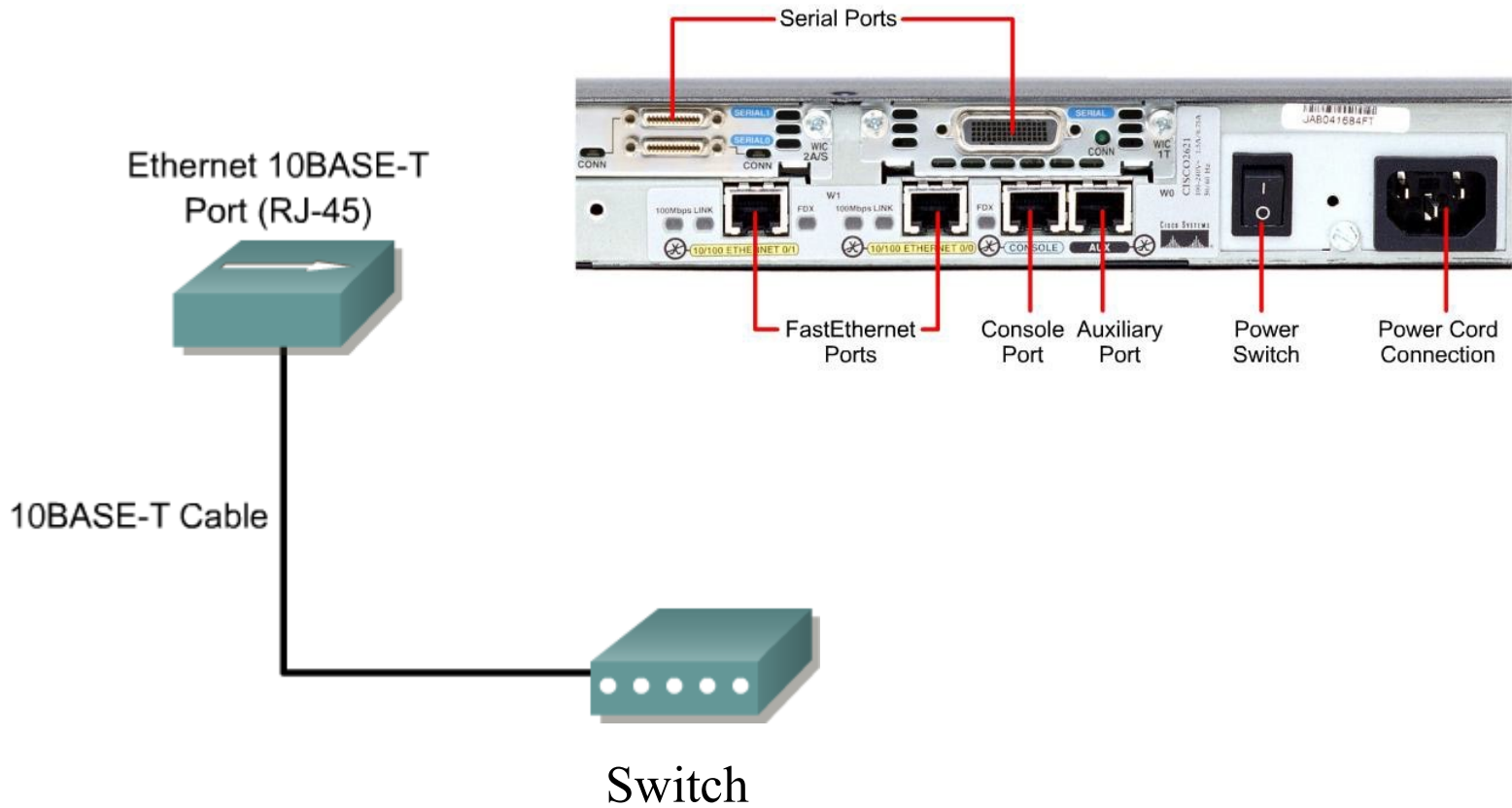

# Connecting WAN interfaces

**Leased Line**

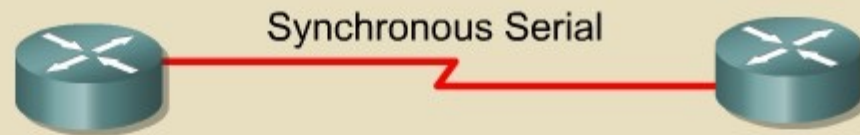

**Circuit-Switched**



**Packet-Switched**



# Connecting WAN interfaces

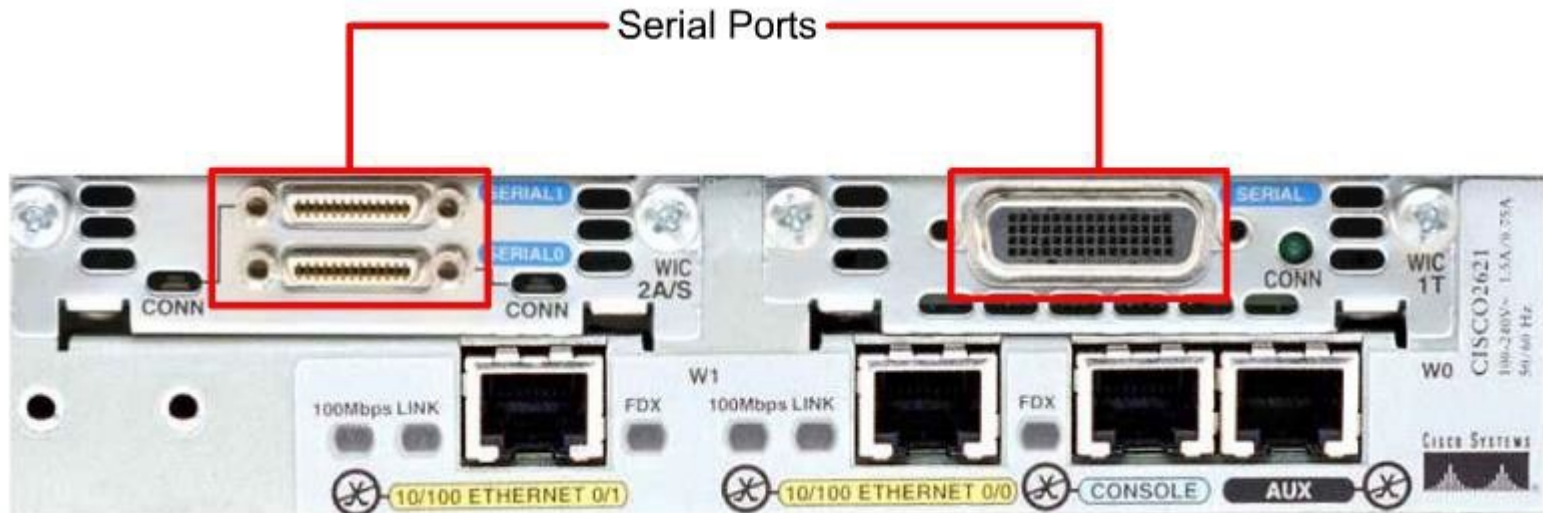

# Connecting WAN interfaces

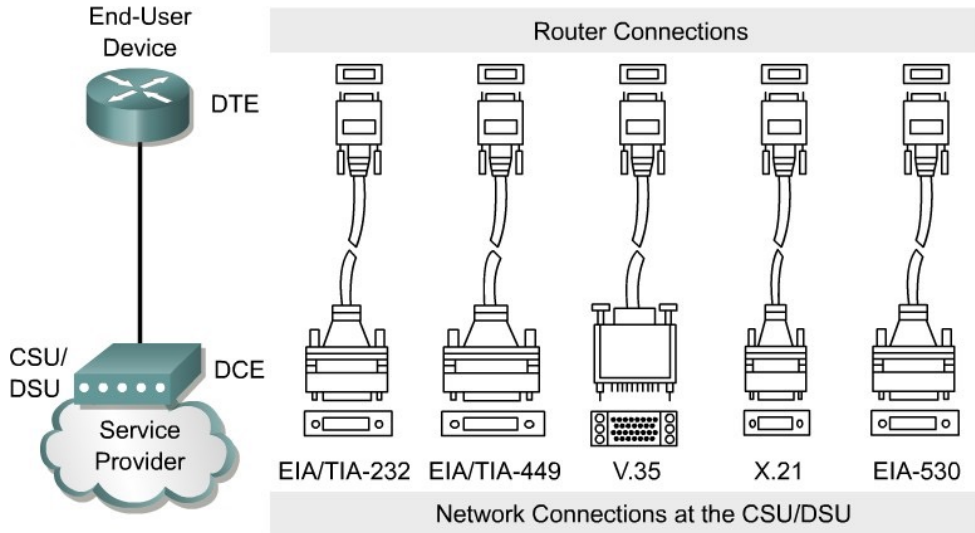

EIA/TIA-232 Male

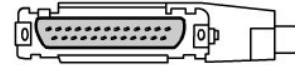

v.35 Male

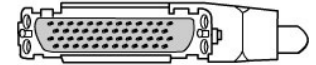

EIA/TIA-232 Female

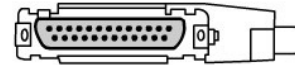

v.35 Female

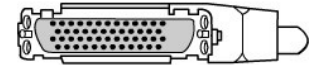

X.21 Male



EIA/TIA - 449 Male

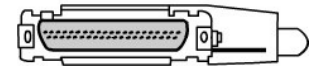

X.21 Female

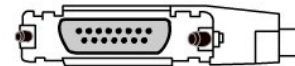

EIA/TIA - 449 Female

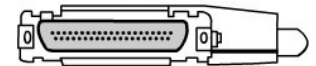

EIA-530 Male



EIA-613 HSSI Male





# Summary

An understanding of the following key points should have been achieved:

- WAN and LAN concepts
- Role of a router in WANs and LANs
- WAN protocols
- Configuring encapsulation
- The identification and description of the internal components of a router
- The physical characteristics of a router
- The standard ports on a router
- How to connect router console, LAN, and WAN ports