

CIS 3210

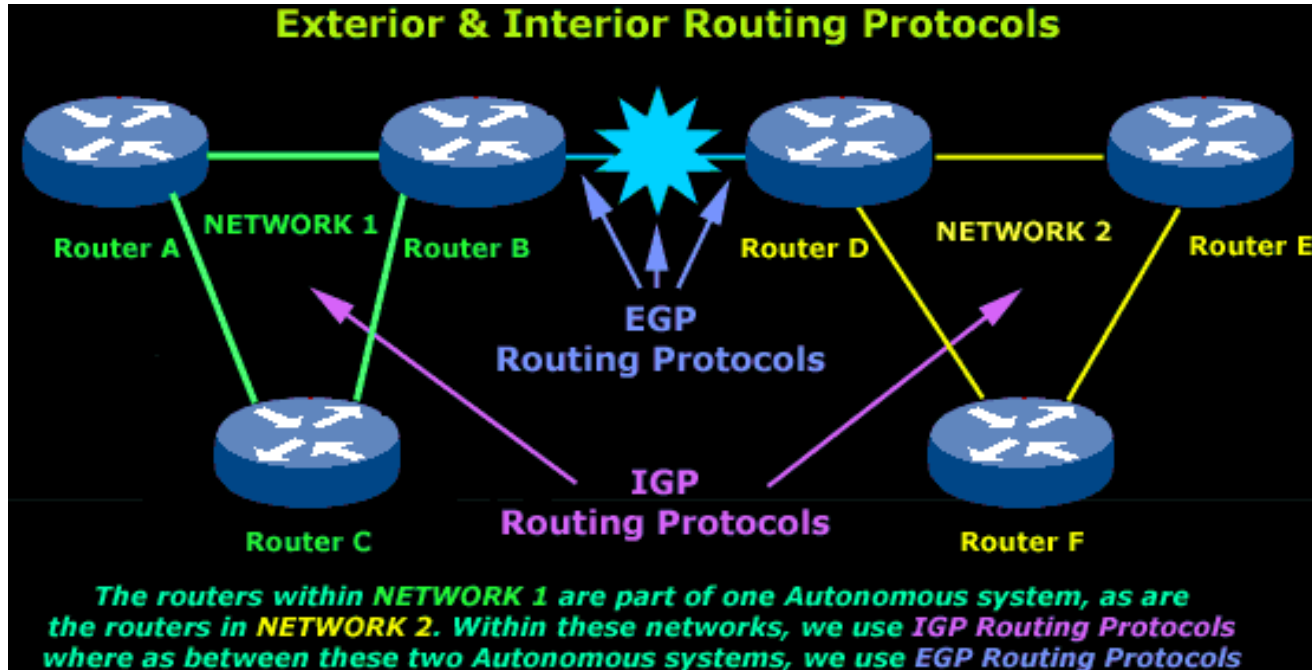

Routing Concepts and Configuration
Jean Hakim (edited by Peter Chapin)
Vermont State University

Note

- This course is about understanding, analyzing, and troubleshooting networks, not how to type commands.
- Example: **show ip route**
 - Type in the command (easy)
 - Explain what the output is displaying (understanding)
 - Explain why you are seeing this information (analyzing)
 - Determine if there is anything missing or if there is something you shouldn't be seeing (troubleshooting)

Network Characteristics and Attributes

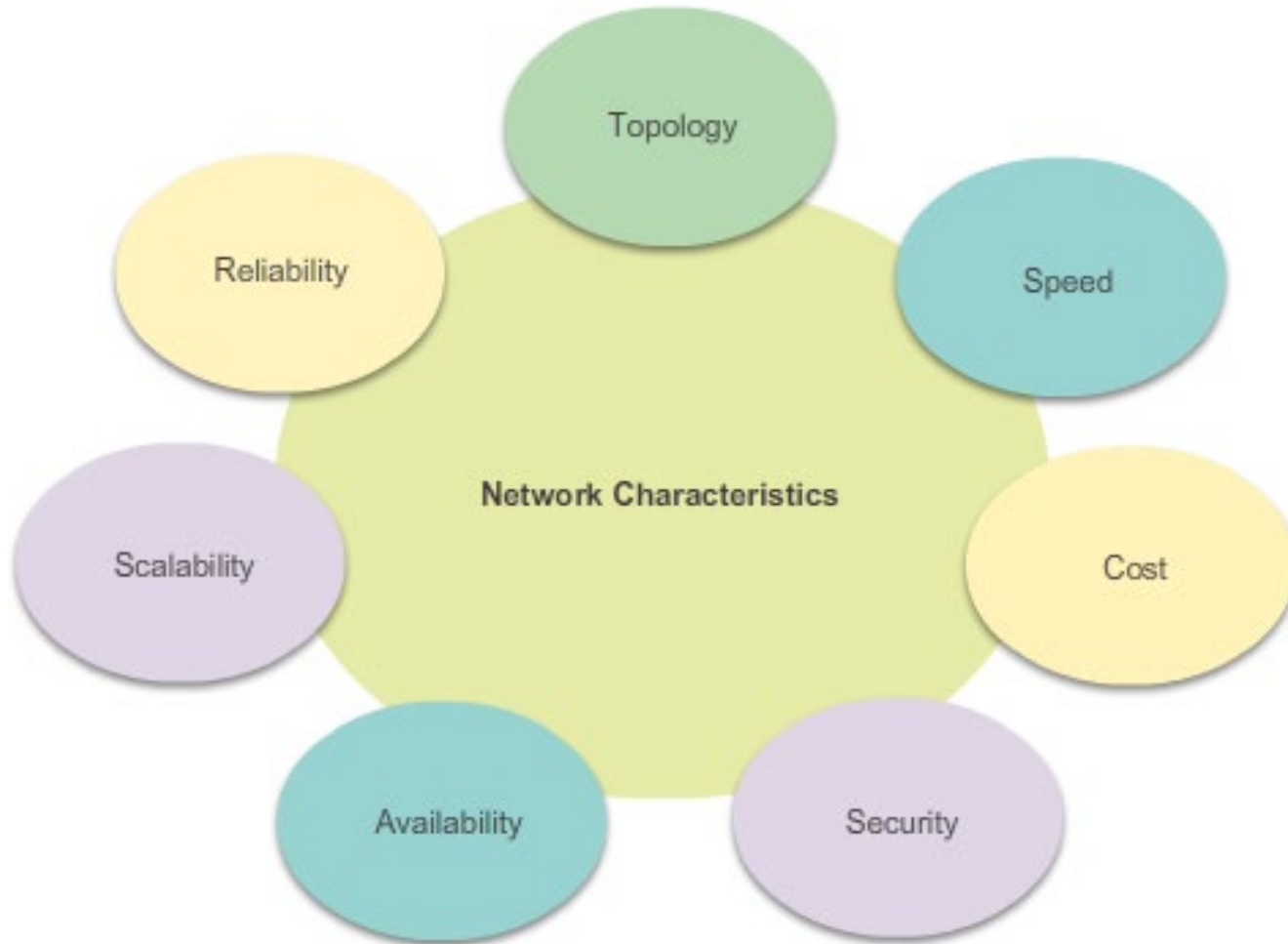

Topology

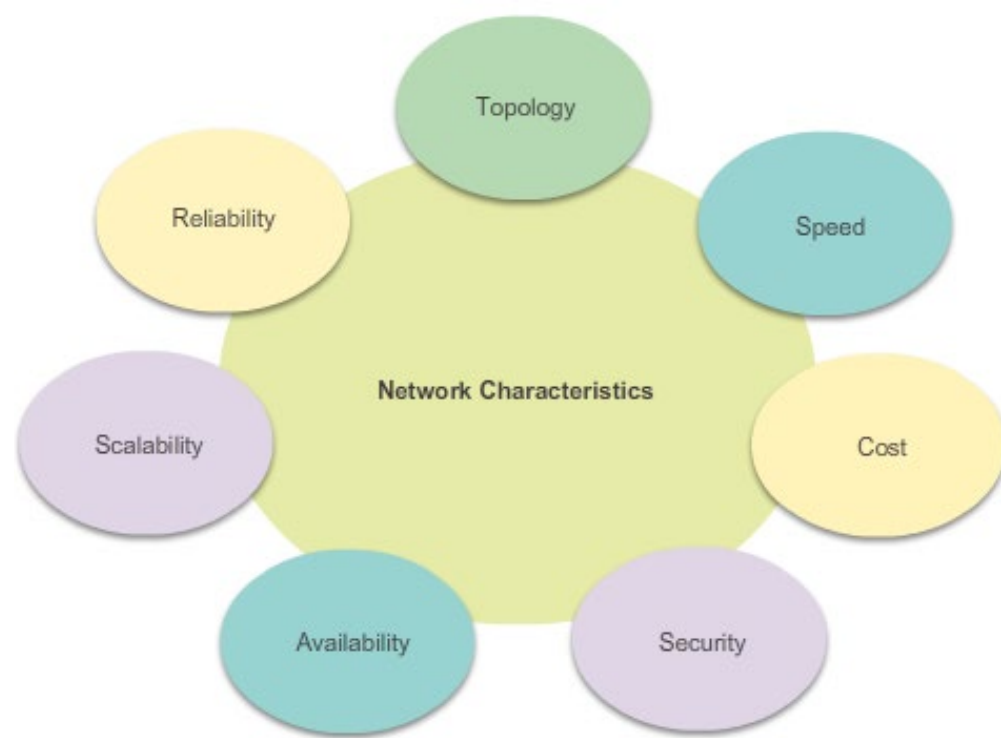

- **Physical Topology:**

- Is the arrangement of the cables, network devices, and end systems.
- It describes how the network devices are actually interconnected with wires and cables.

- **Logical Topology:**

- Is the path over which the data is transferred in a network.
- It describes how the network devices appear connected to network users.

Network Attributes

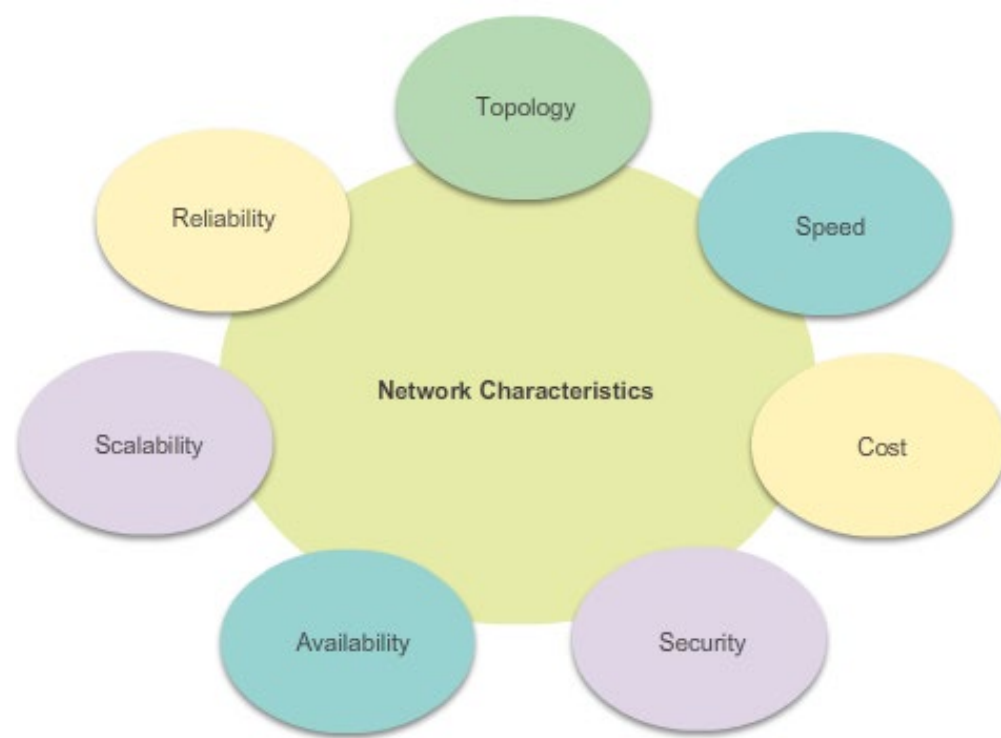

- **Speed:**
 - The measure of the data rate in bits per second (b/s) of a given link.
- **Cost:**
 - Indicates the general expense for purchasing of network components, and installation and maintenance of the network.
- **Security:**
 - Indicates how protected the network is, including the information that is transmitted over the network.

Network Attributes

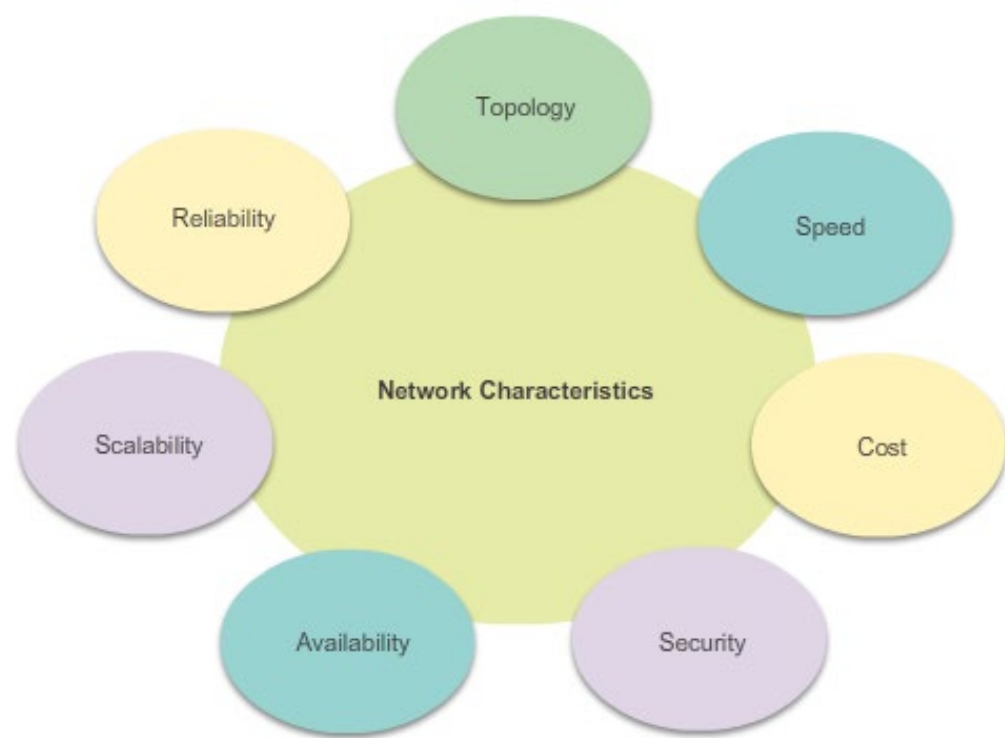

- **Availability:**
 - Is a measure of the probability that the network is available for use when it is required.
- **Scalability:**
 - Indicates how easily the network can accommodate more users and data transmission requirements.
- **Reliability:**
 - Indicates the dependability of the components that make up the network, such as the routers, switches, PCs, and servers.
 - Often measured as a probability of failure or as the mean time between failures (MTBF).

Routers

Why Routing?

The router is responsible for the routing of traffic between networks.

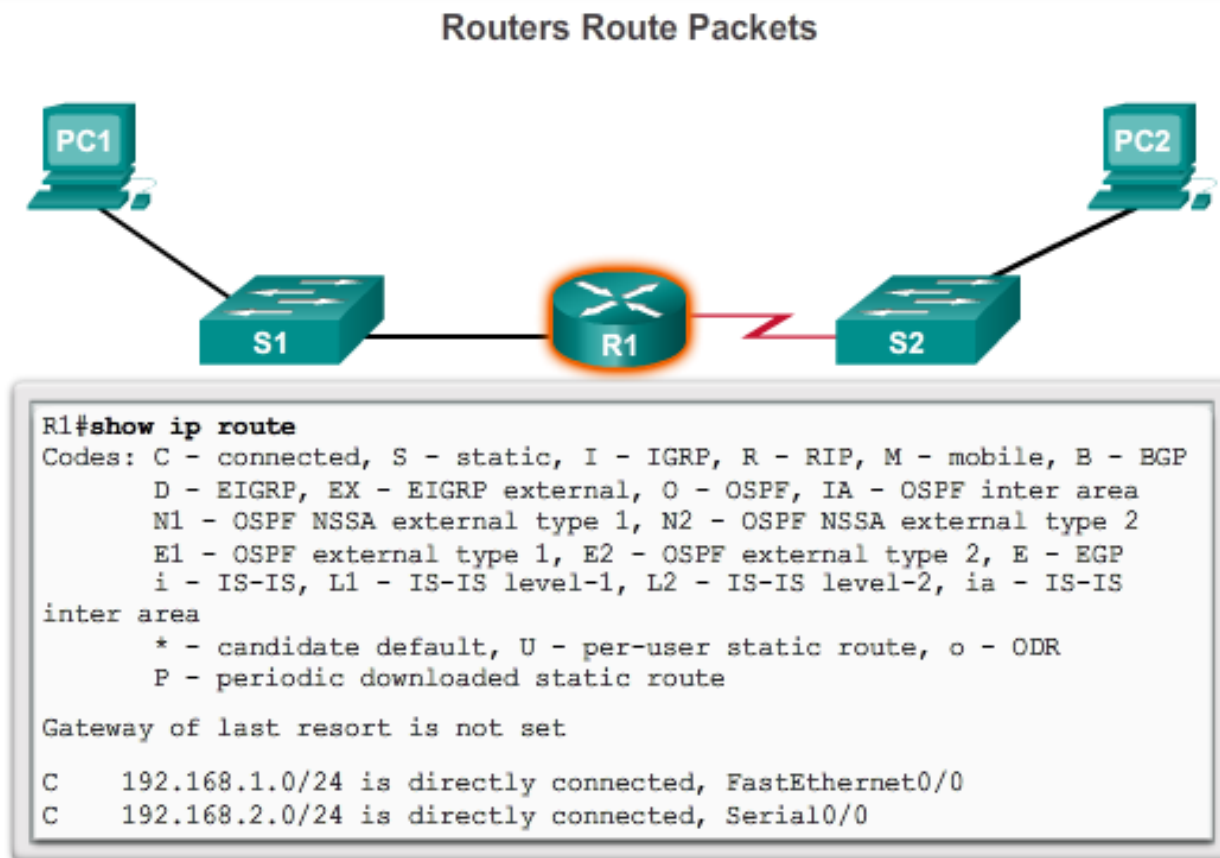

Cisco IOS command line interface (CLI) can be used to view the route table.

CIS 3210

What is a Router?



Leonard Kleinrock and the first IMP.

- A router is a specialized computer!
 - It sends packets over the data network.
- It is responsible for interconnecting networks by selecting the best path for a packet to travel and forwarding packets to their destination
- The first router (ARPANET):
 - IMP (Interface Message Processor)
 - Honeywell 516 minicomputer
 - August 30, 1969

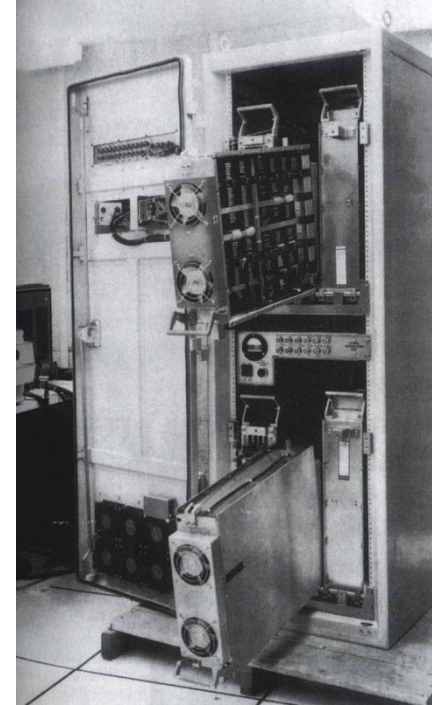

Router Components

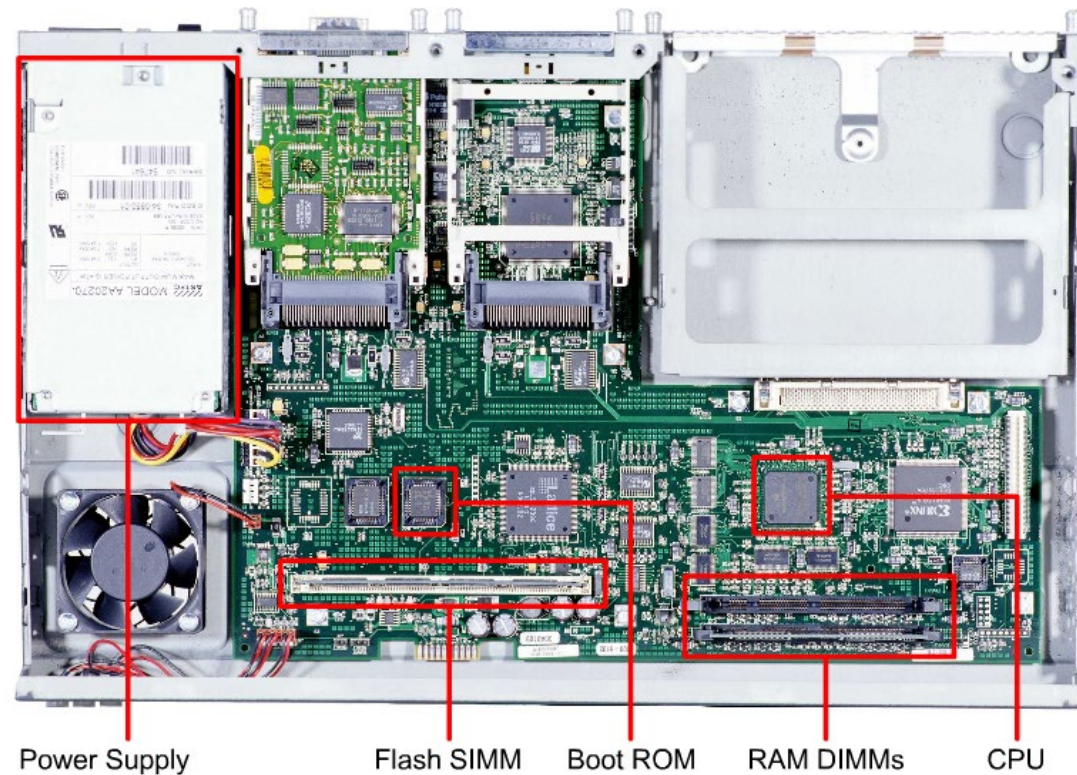

- Regardless of their function, size or complexity, all router models are essentially computers and require:
 - Operating systems (OS)
 - Central processing units (CPU)
 - Random-access memory (RAM)
 - Read-only memory (ROM)
- *Routers also have special memory that includes Flash and non-volatile random-access memory (NVRAM).*

Router Backplane

- The backplane of a router includes:

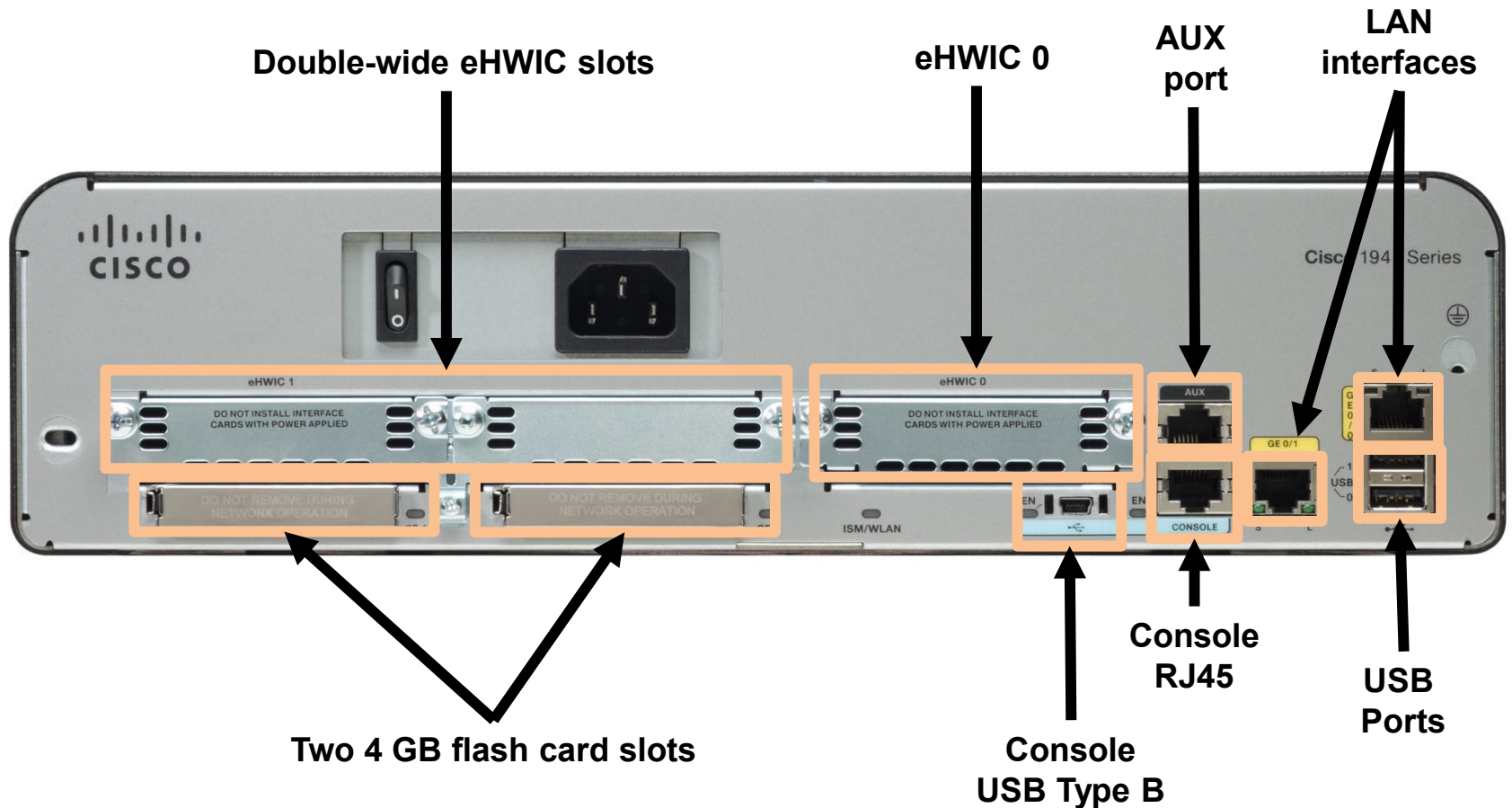

Routers vs Multilayer Switches



- Routers and multilayer switches both perform routing (connecting networks)
- Routers may have different types of interfaces (Ethernet, serial, ATM, etc.) while multilayer switches will only have Ethernet interfaces.
- While routers can be used to segment LAN devices, their major use is as WAN devices.
- Each devices does have its own advantages.

Routers in LANs and WANs

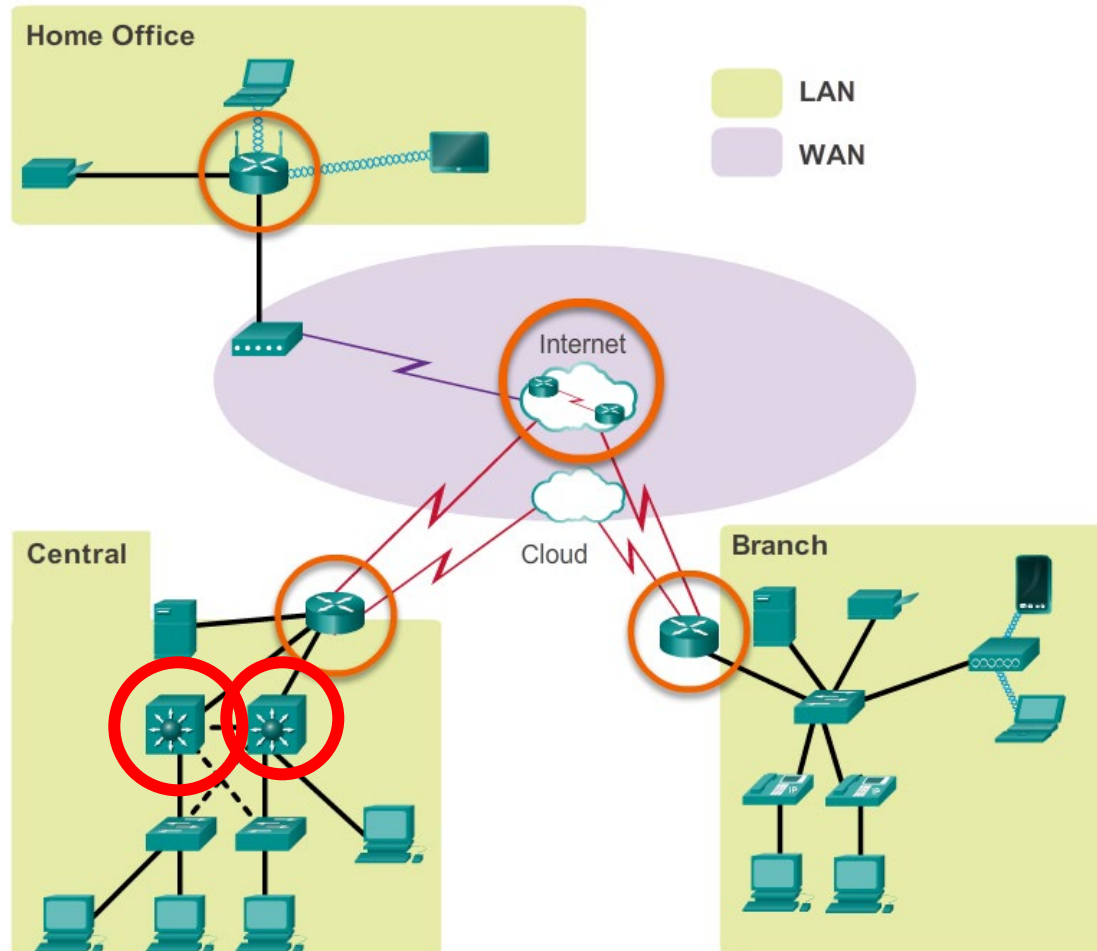

- Routers can connect multiple networks.
- Routers have multiple interfaces, each on a different IP network.

Best Path Decisions

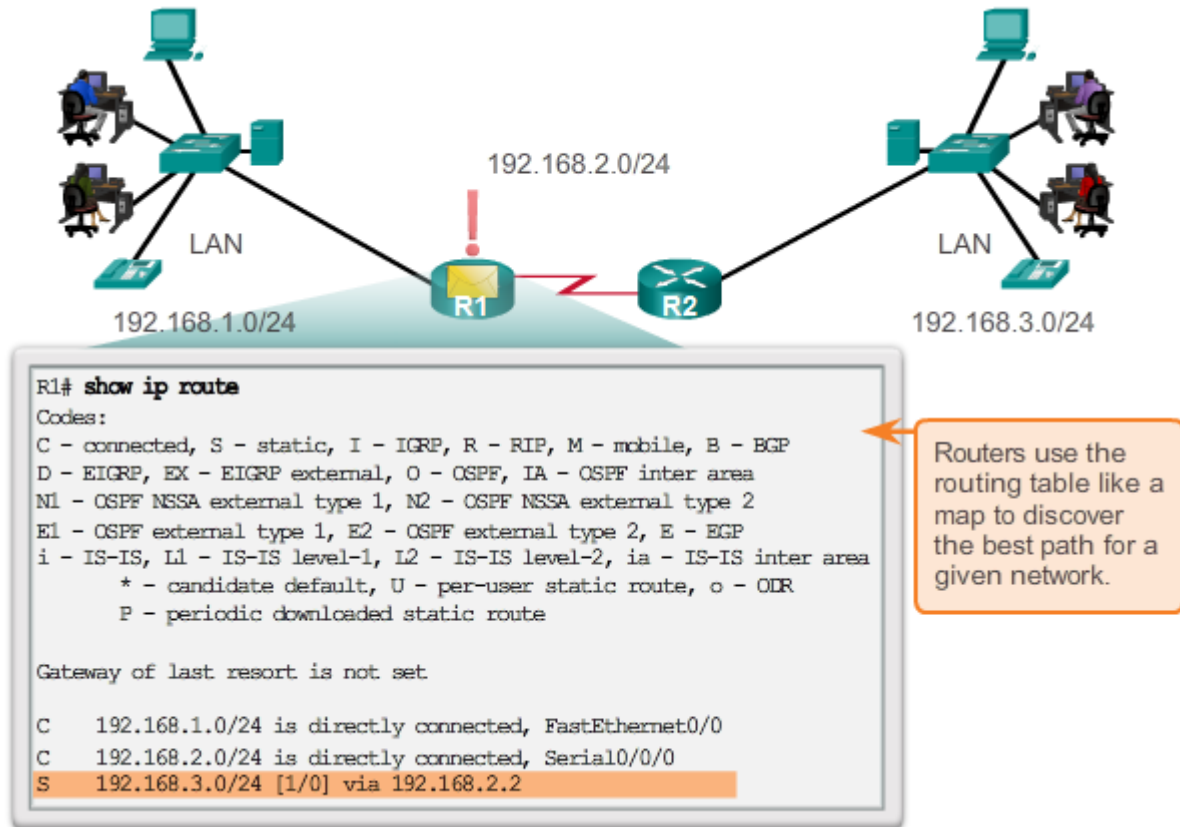

- The primary responsibility of a router is to direct packets by:
 - Determining the best path to send packets
 - Forwarding packets toward their destination

Best Path Decisions

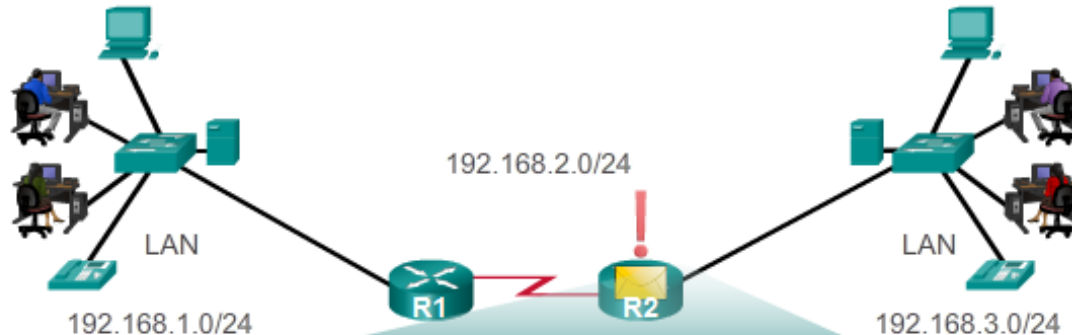

R2 follows the same process.

```
R2# show ip route
```

```
Codes:
```

```
C - connected, S - static, I - IGRP, R - RIP, M - mobile, B - BGP  
D - EIGRP, EX - EIGRP external, O - OSPF, IA - OSPF inter area  
N1 - OSPF NSSA external type 1, N2 - OSPF NSSA external type 2  
E1 - OSPF external type 1, E2 - OSPF external type 2, E - EGP  
i - IS-IS, L1 - IS-IS level-1, L2 - IS-IS level-2, ia - IS-IS inter area  
* - candidate default, U - per-user static route, o - ODR  
P - periodic downloaded static route
```

```
Gateway of last resort is not set
```

```
C 192.168.3.0/24 is directly connected, FastEthernet0/0  
C 192.168.2.0/24 is directly connected, Serial0/0/0  
S 192.168.1.0/24 [1/0] via 192.168.2.1
```

- Routers use routing tables to determine the best path to send packets.
- Routers *encapsulate* the packet and forward it to the interface indicated in routing table.

Router Functions

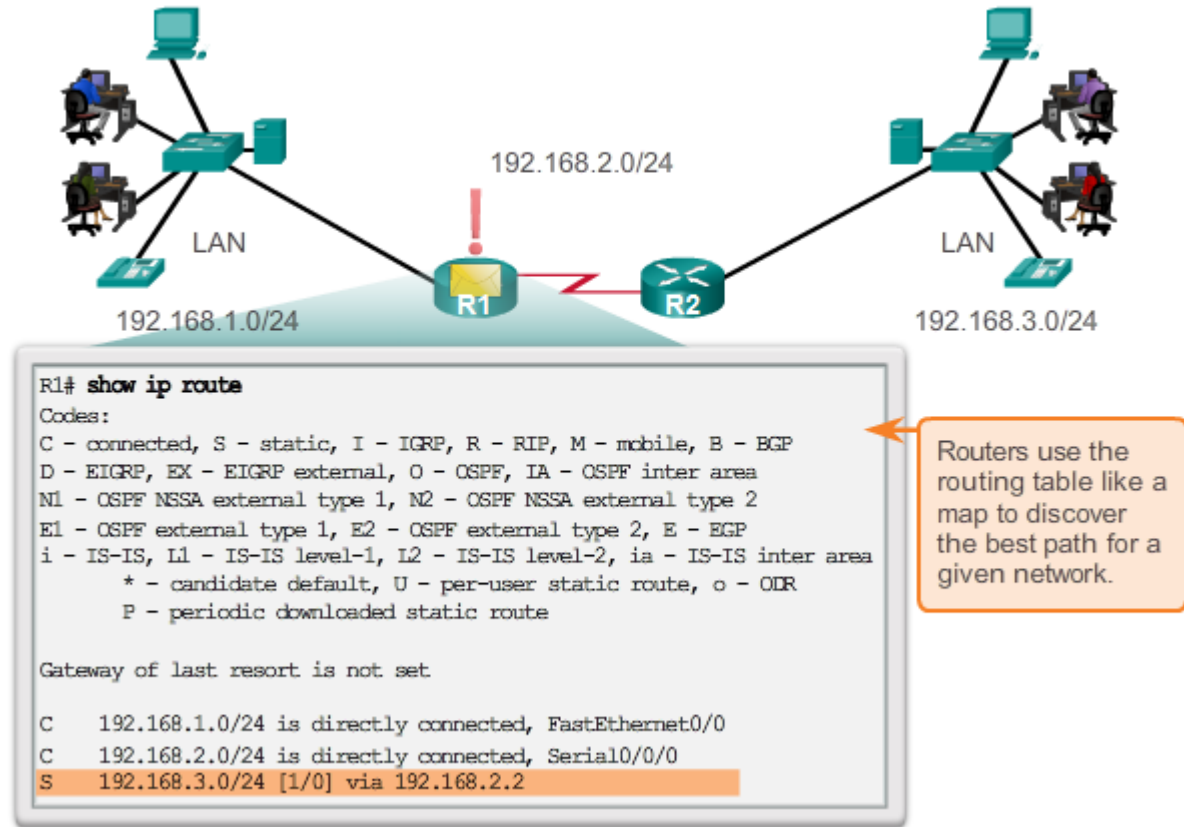

- Routing tables can be created:
 - Manually with static routes
 - Dynamically with routing protocols
- Routing protocols exchanges network topology (path) information with other routers.

Best Path Decisions

- The router uses its routing table to determine the best path to forward the packet.
 - The router examines its destination IP address of received packets and searches for the best match in the routing table.
 - The routing table entries also includes the interface to be used to forward the packet.
 - Once a match is found, the router encapsulates the IP packet into the data link frame of the outgoing or exit interface.
 - The packet is then forwarded toward its destination.
- Routers support three packet-forwarding mechanisms:
 - Process switching
 - Fast Switching
 - Cisco Express Forwarding (CEF)

Process Switching

Analogy: Process switching solves a problem by doing math long hand, even if it is the identical problem.

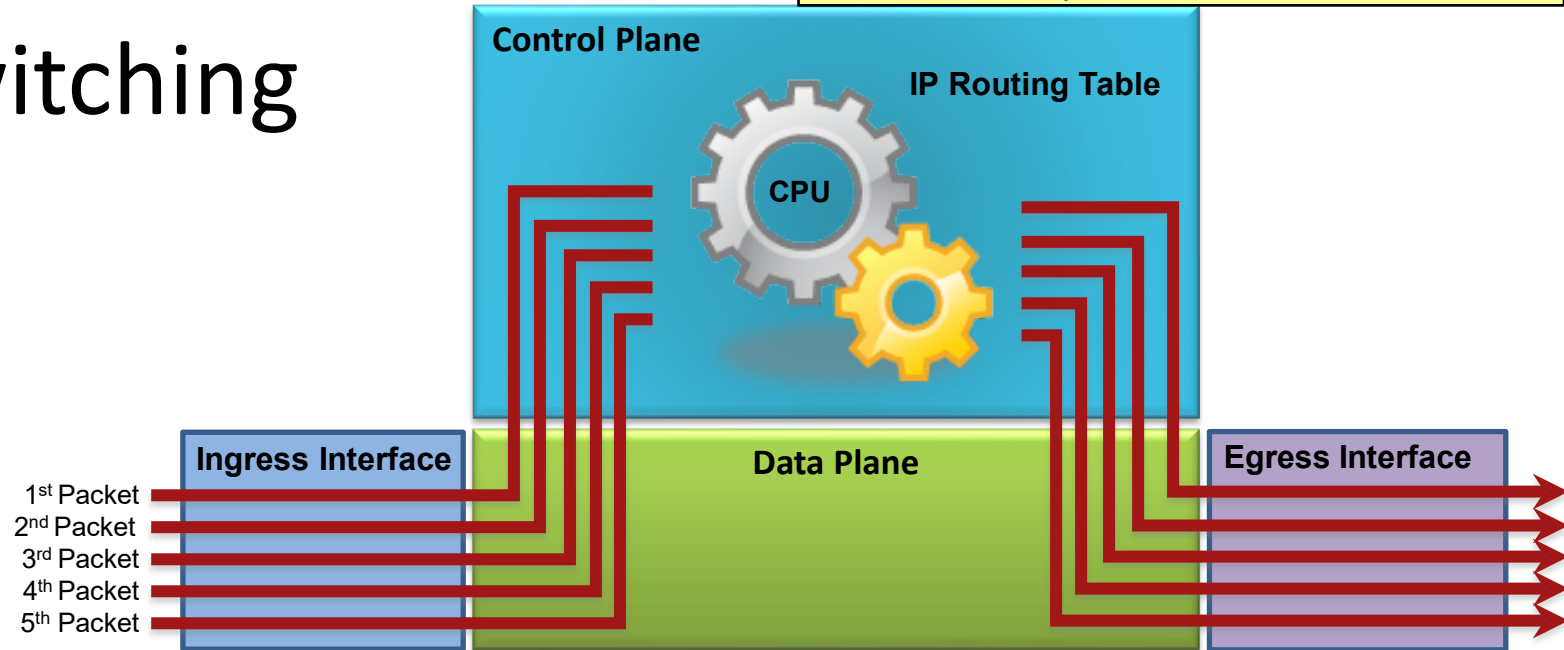

- Earliest switching method. (Applies to both routers and multilayer switches.)
- This is an older packet forwarding mechanism.
 - When a packet arrives on an interface, it is forwarded to the control plane where the CPU examines the routing table, determines the exit interface and forwards the packet.
 - It does this for every packet, even if the destination is the same for a stream of packets.

Analogy: Fast switching solves a problem by doing math long hand one time and remembering the answer for subsequent identical problems.

Fast Switching

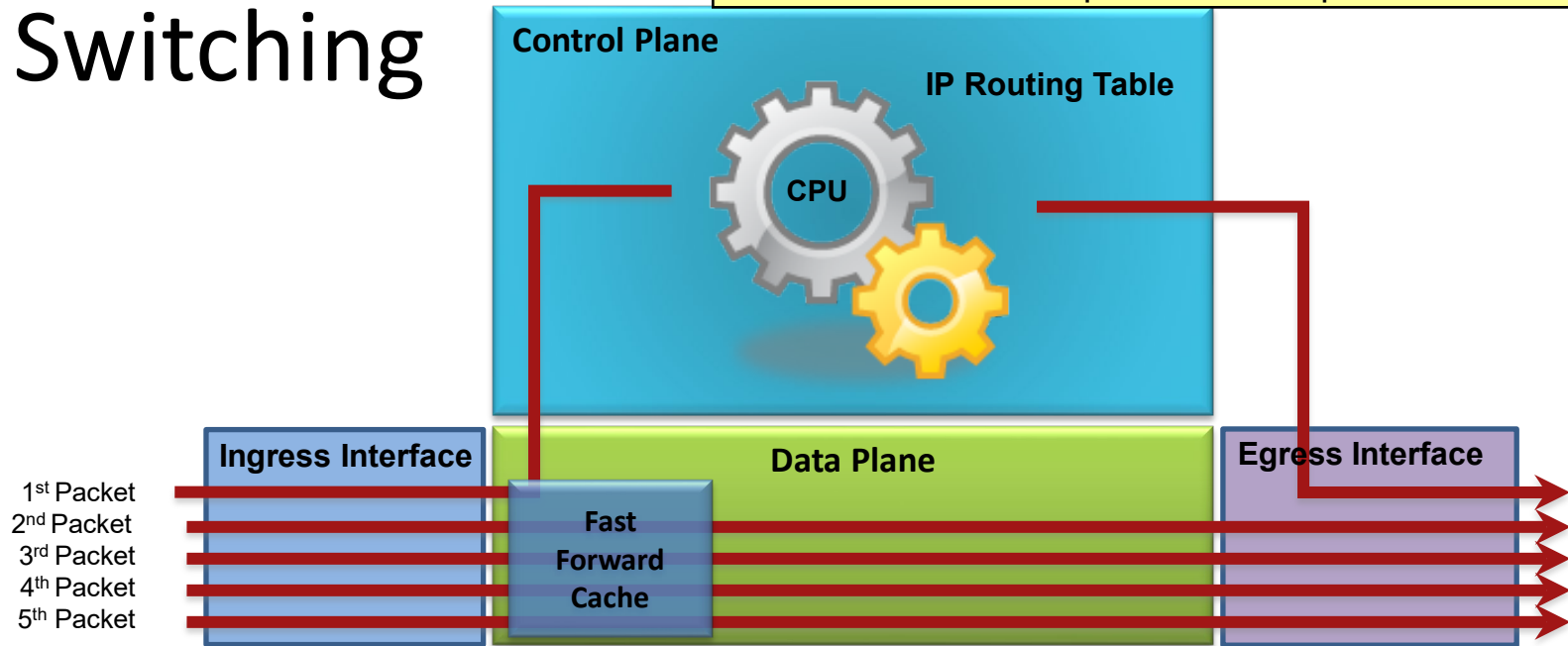

- As routers had to process more packets, it was determined process switching was not fast enough.
- Next evolution in packet switching was Fast Switching. (Applies to both routers and multilayer switches.)
 - The first packet is process-switched (CPU + routing table) but it also uses a fast-switching cache to store next-hop information of the flow.
 - The next packets in the flow are forwarded using the cache and without CPU intervention.

CEF Switching

Analogy: CEF solves every possible problem ahead of time in a spreadsheet.

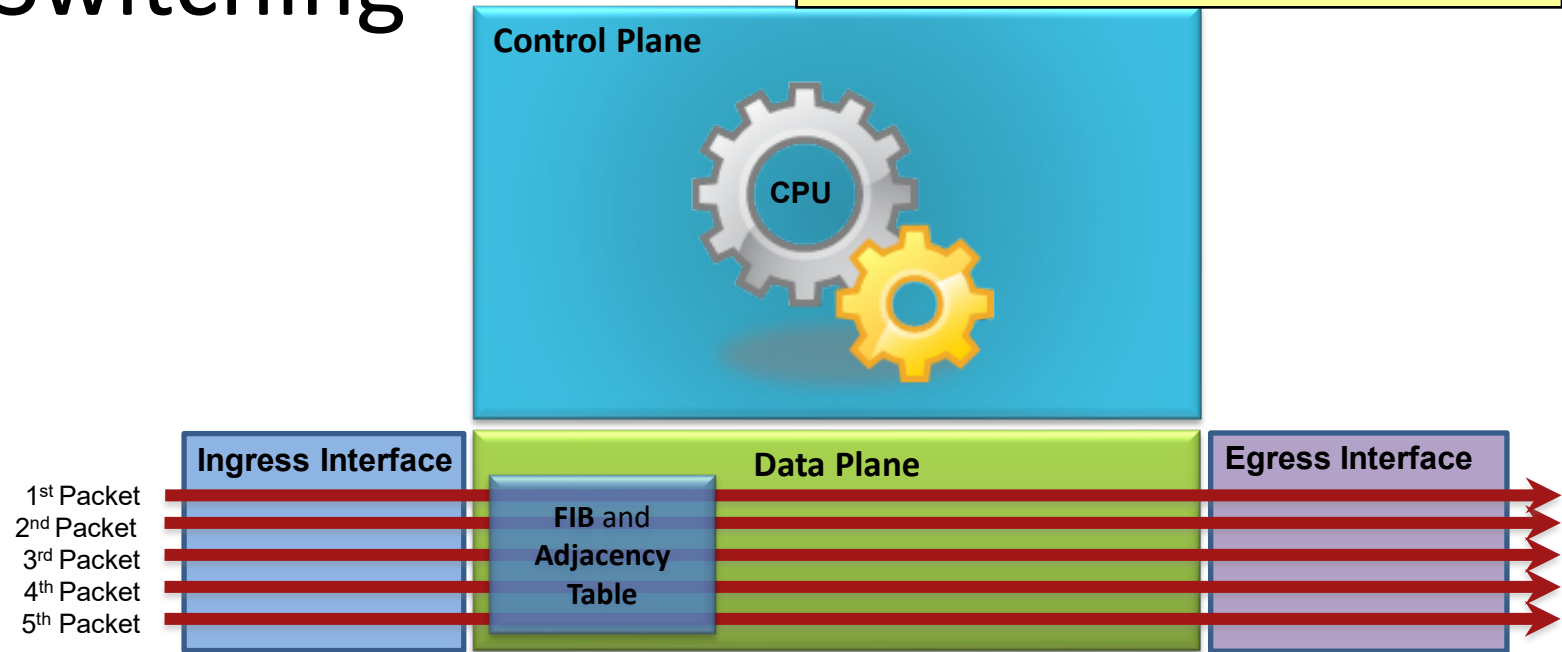

- Preferred and default Cisco IOS packet-forwarding mechanism for routers and multilayer switches.
 - CEF copies the routing table to the Forwarding Information Base (FIB)
 - CEF creates an adjacency table which contains all the layer 2 information a router would have to consider when forwarding a packet such as Ethernet destination MAC address.
 - The adjacency table is created from the ARP table.

Home Office Devices Connect ...

- Laptops and tablets connect wirelessly to a home router.
- A network printer connects using an Ethernet cable to the switch port on the home router.
- The home router connects to the service provider cable modem using an Ethernet cable.
- The cable modem connects to the Internet service provider (ISP) network.

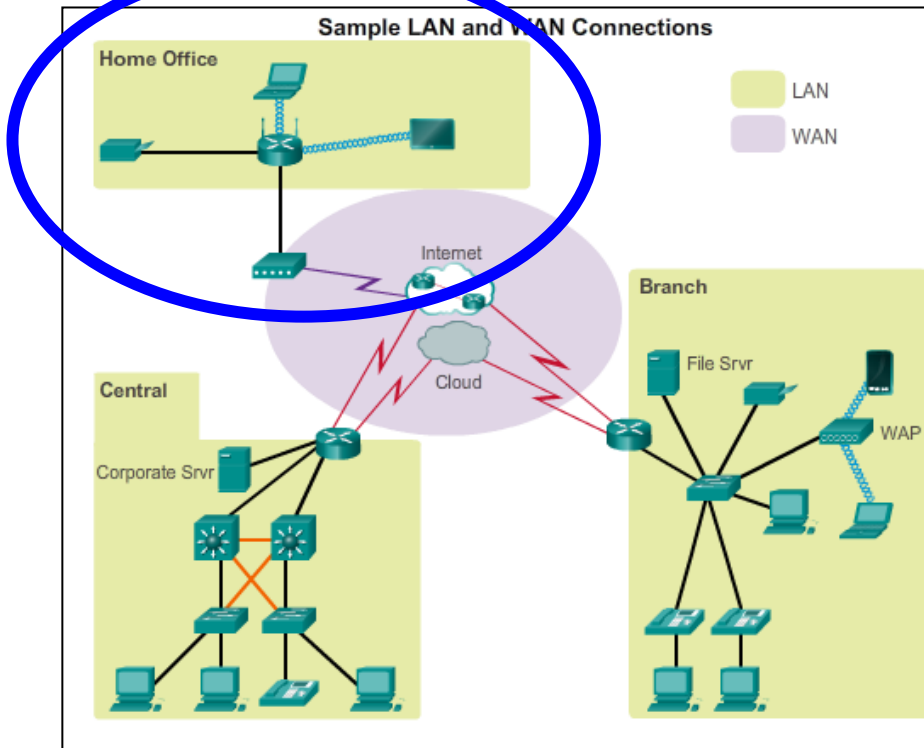

Branch Site Devices Connect ...

- Corporate resources (i.e., file servers and printers) connect to Layer 2 switches.
- PCs and VoIP phones connect to Layer 2 Ethernet switches.
- Laptops and smartphones connect wirelessly to WAPs.
- WAPs connect to switches.
- Layer 2 switches connect to the edge router.
- The edge router connects to a WAN service provider (SP) and an ISP for backup purposes.

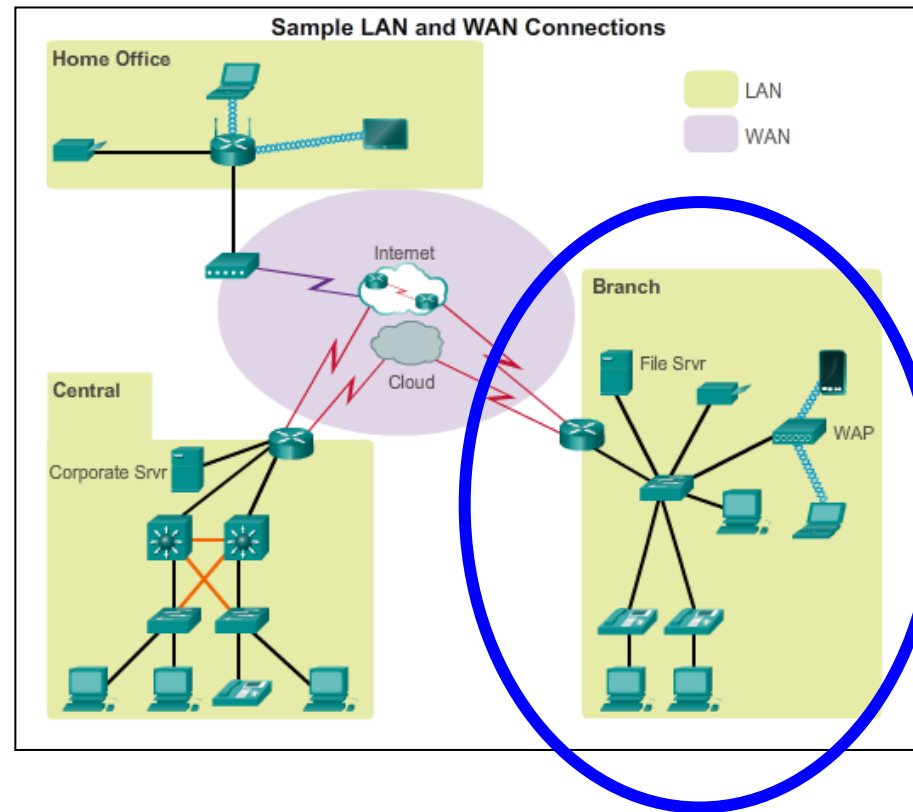

Central Site Devices Connect ...

- PCs and VoIP phones connect to Layer 2 Ethernet switches.
- Layer 2 switches connect to Layer 3 switches using Ethernet fiber-optic cables.
- Layer 3 switches connect to the edge router.
- The corporate website server is connected to the edge router interface.
- The edge router connects to a WAN SP and an ISP for backup purposes.

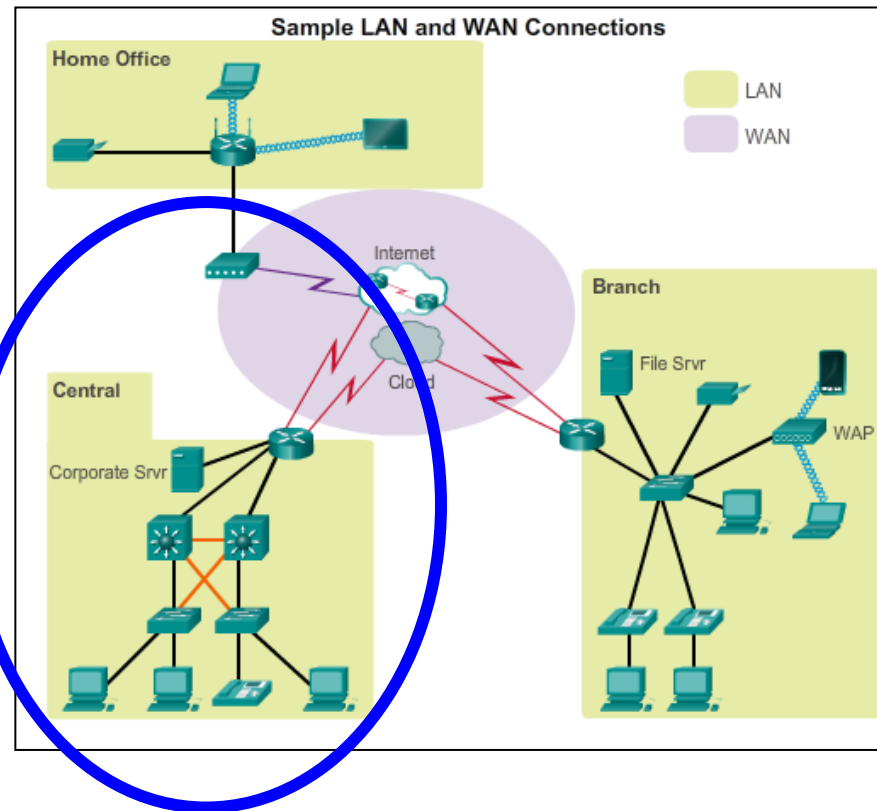

Destination MAC Address	Source MAC Address	Source IP Address	Destination MAC Address	Data
11-11-11-11-11-11	AA-AA-AA-AA-AA-AA	192.168.1.110	172.16.1.99	

Default Gateways

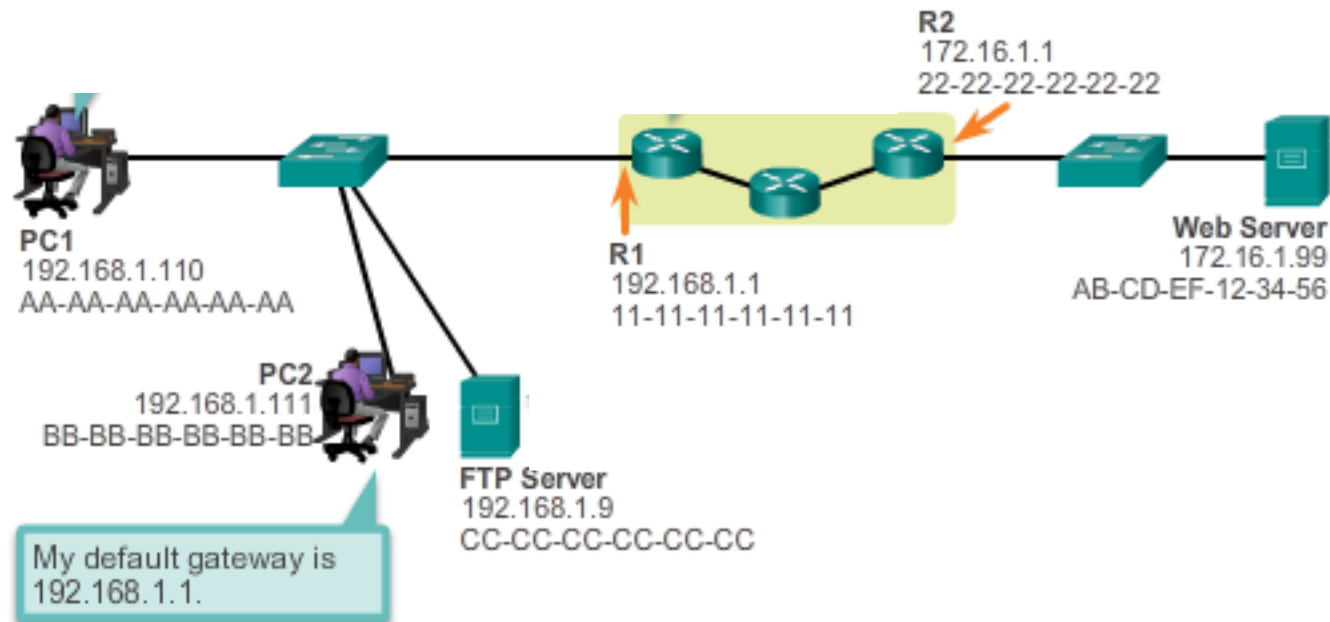

- To enable network access, devices must be configured with IP address information to identify the appropriate:
 - **IP address** - Identifies a unique host on a local network.
 - **Subnet mask** - Identifies with which network subnet the host can communicate.
 - **Default gateway** - Identifies the router to send a packet to when the destination is not on the same local network subnet.

Documenting a Network

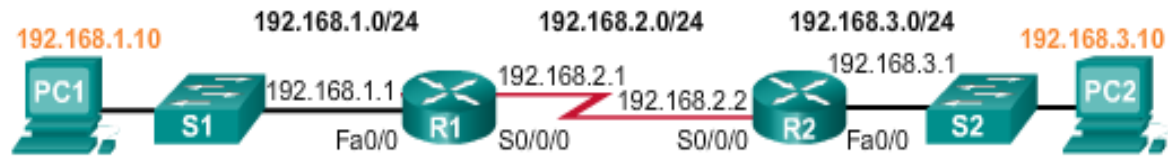

Device	Interface	IP Address	Subnet Mask	Default Gateway
R1	Fa0/0	192.168.1.1	255.255.255.0	N/A
	S0/0/0	192.168.2.1	255.255.255.0	N/A
R2	Fa0/0	192.168.3.1	255.255.255.0	N/A
	S0/0/0	192.168.2.2	255.255.255.0	N/A
PC1	N/A	192.168.1.10	255.255.255.0	192.168.1.1
PC2	N/A	192.168.3.10	255.255.255.0	192.168.3.1

- Network documentation should identify:
 - Device names
 - Interfaces used in the design
 - IP addresses and subnet masks
 - Default gateway addresses
- Useful documents include:
 - Network topology diagram
 - Addressing Table

Documenting a Network

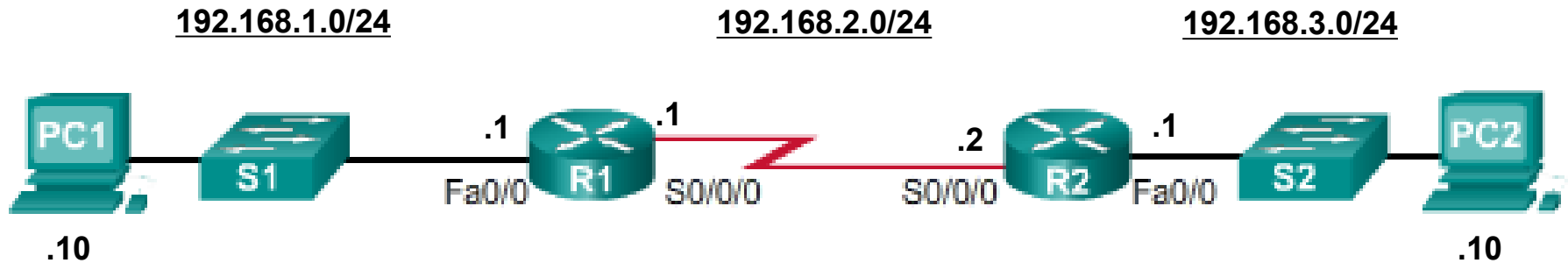

Device	Interface	IP Address	Subnet Mask	Default Gateway
R1	Fa0/0	192.168.1.1	255.255.255.0	N/A
	S0/0/0	192.168.2.1	255.255.255.0	N/A
R2	Fa0/0	192.168.3.1	255.255.255.0	N/A
	S0/0/0	192.168.2.2	255.255.255.0	N/A
PC1	N/A	192.168.1.10	255.255.255.0	192.168.1.1
PC2	N/A	192.168.3.10	255.255.255.0	192.168.3.1

Hosts Addressing

- A host can be assigned IP address information either:
 - **Statically** - The host is manually assigned the correct IP address, subnet mask, and default gateway. The DNS server IP address can also be configured.
 - **Dynamically** - IP address information is provided by a server using the Dynamic Host Configuration Protocol (DHCP).

The DHCP server provides a valid IP address, subnet mask, and default gateway for end devices. Other information may be provided by the server.

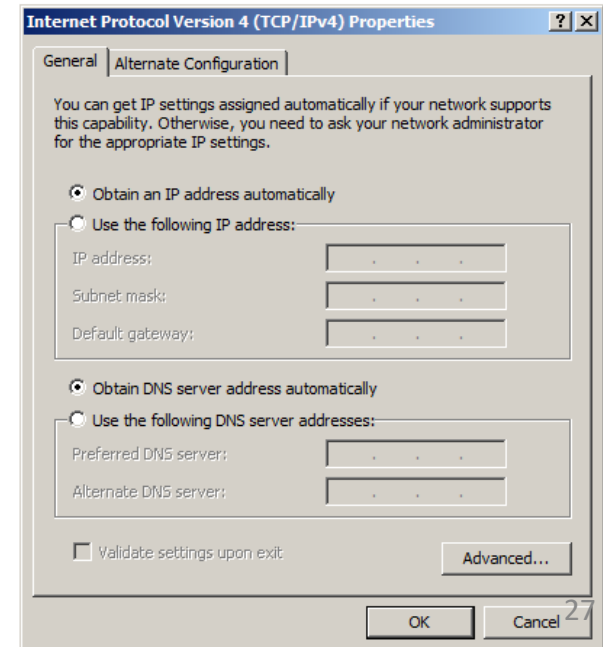
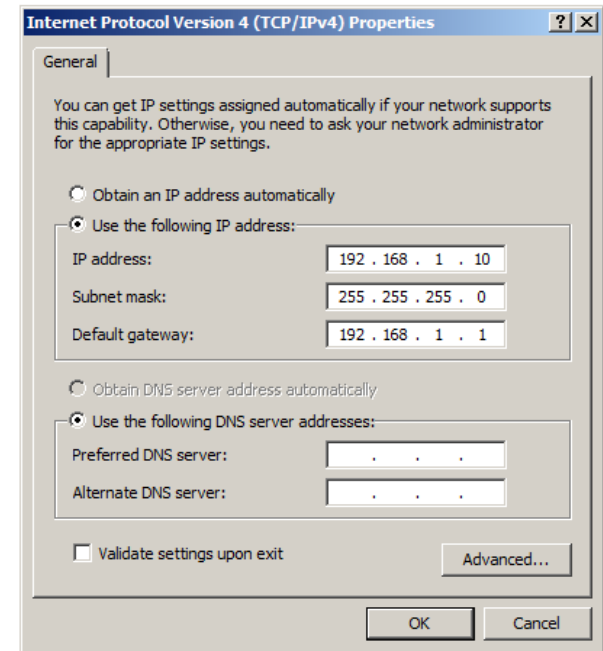

Device LEDs

#	Port	LED	Color	Description
1	GE0/0 and GE0/1	S (Speed)	1 blink + pause	Port operating at 10 Mb/s
			2 blink + pause	Port operating at 100 Mb/s
			3 blink + pause	Port operating at 1000 Mb/s
		L (Link)	Green	Link is active
			Off	Link is inactive
2	Console	EN	Green	Port is active
			Off	Port is inactive
			Off	Port is inactive
3	USB	EN	Green	Port is active
			Off	Port is inactive
			Off	Port is inactive

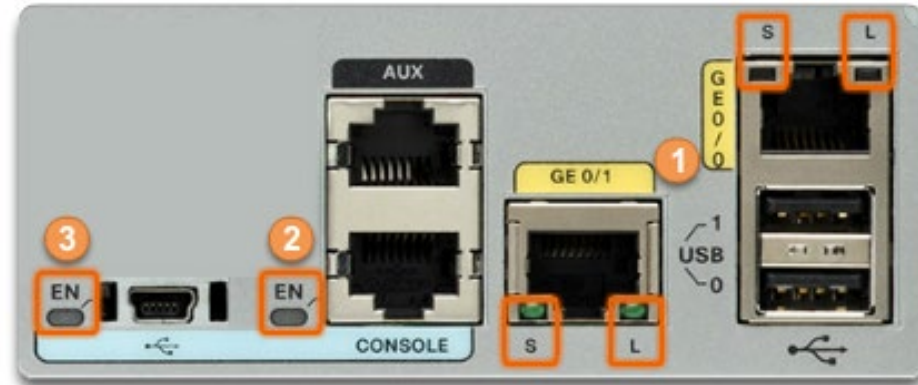

- Most network interfaces have one or two LED link indicators next to the interface.
- Generally:
 - Green LED means a good connection
 - Blinking green LED indicates network activity.
 - No light then there may be a problem with either the network cable or the network itself.
- The switch port where the connection terminates would also have an LED indicator lit.
 - If one or both ends are not lit, try a different network cable.

Console Connection

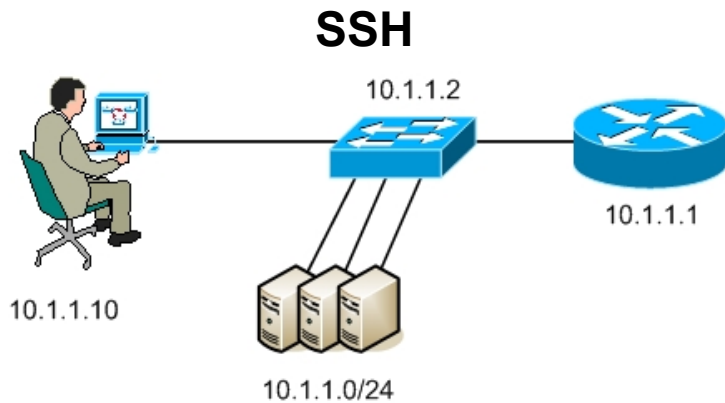

Console Connection

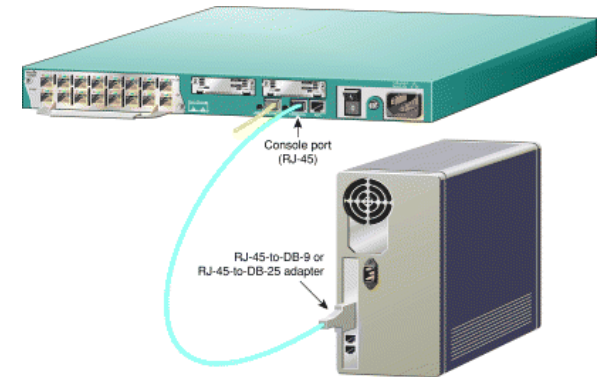







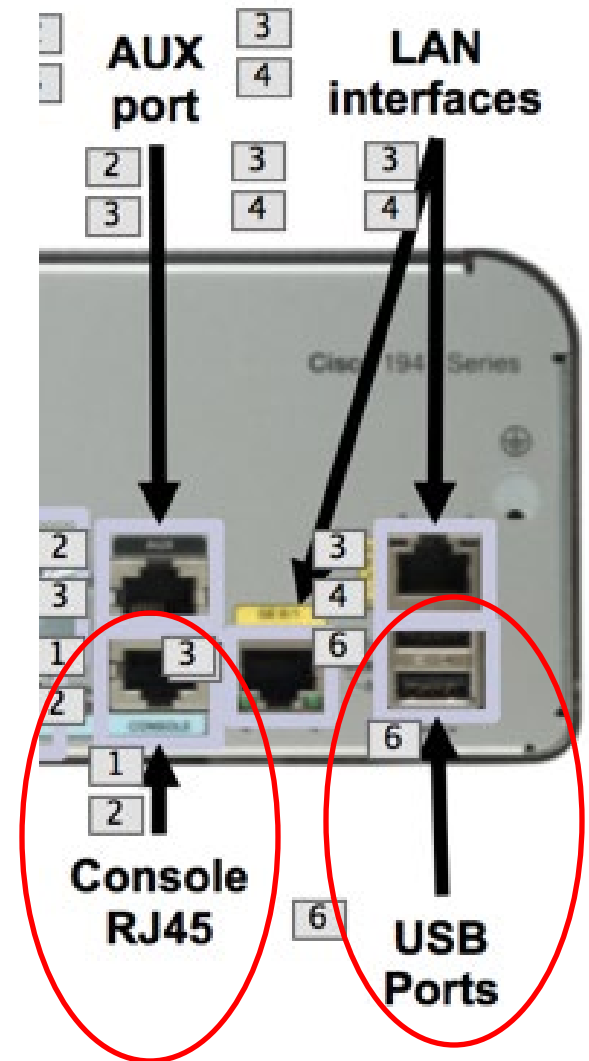

- In a production environment, infrastructure devices are commonly accessed remotely using Secure Shell (SSH) or Hypertext Transfer Protocol Secure (HTTPS).
- Console access is really only required when initially configuring a device, if remote access fails, or if the change may affect the remote access.
- Console access requires:
 - **Console cable** – RJ-45-to-DB-9 console cable
 - **Terminal emulation software** – Tera Term, PuTTY, etc.

USB Serial Console Connection

- The Cisco ISR G2 supports a USB serial console connection.
 - To establish connectivity, a USB Type-A to USB Type-B (mini-B USB) is required, as well as an operating system device driver.
 - This device driver is available from <http://www.cisco.com>.
- Although these routers have two console ports, only one console port can be active at a time.
 - When a cable is plugged into the USB console port, the RJ-45 port becomes inactive.
 - When the USB cable is removed from the USB port, the RJ-45 port becomes active.

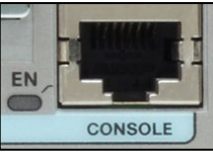

Console Connection Requirements

Port on Computer	Cable required	Port on ISR	Terminal emulation
			 <p>Tera Term</p>
<p>USB Type-A port</p> 		<p>RJ45 Console port</p> 	 <p>PuTTY</p>
			

Configuring Routers

Name the Device

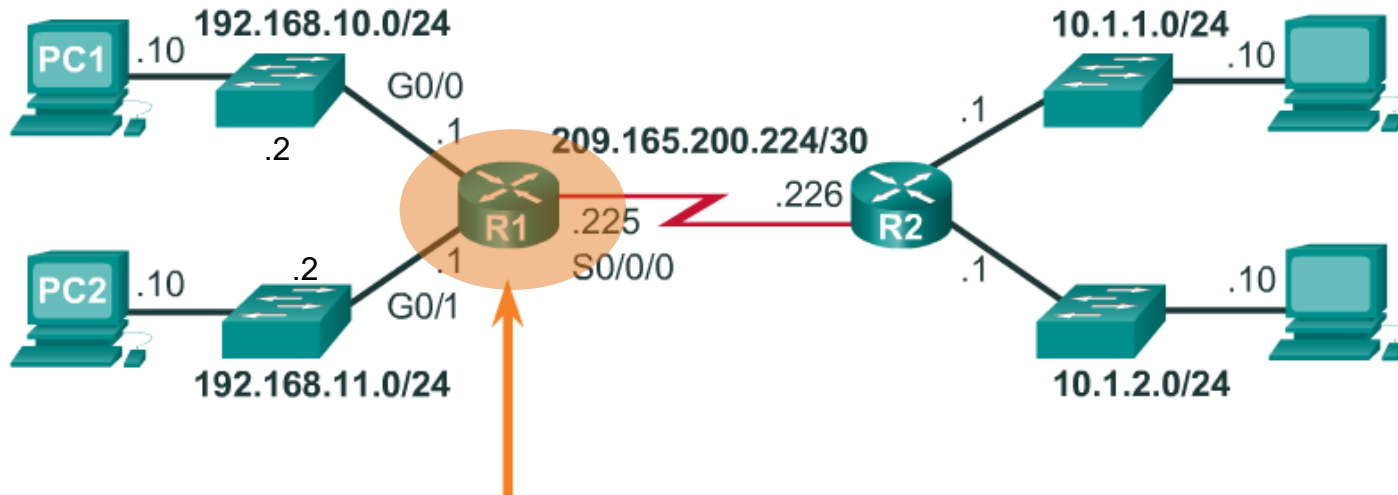

```
Router# configure terminal  
Enter configuration commands, one per line. End with CNTL/Z.  
Router(config)# hostname R1  
R1(config)#
```

Secure Management Access

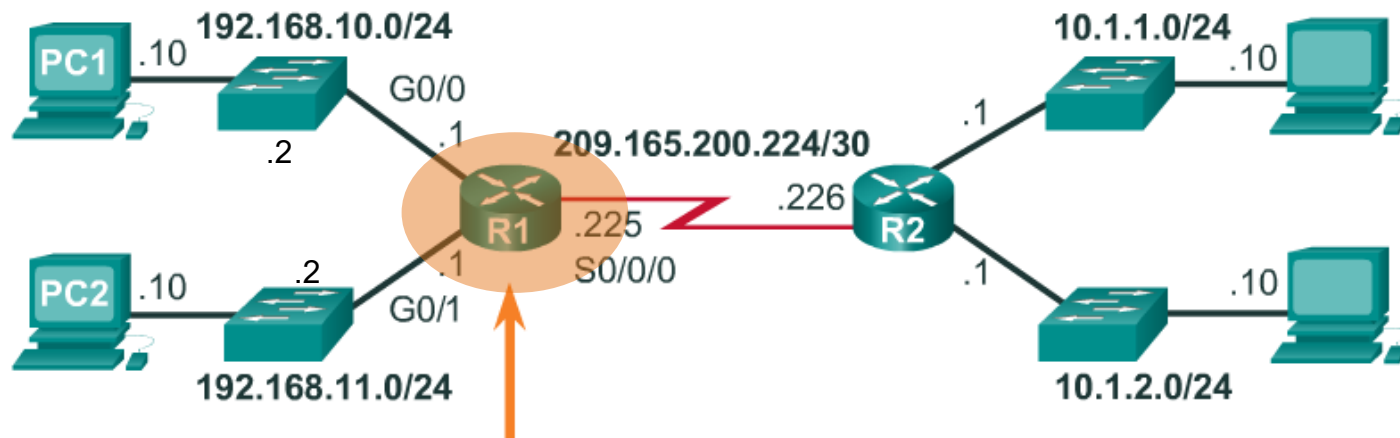

```
R1 (config) # enable secret hotdog
R1 (config) #
R1 (config) # line console 0
R1 (config-line) # password hamburger
R1 (config-line) # login
R1 (config-line) # exit
R1 (config) # line vty 0 15
R1 (config-line) # password hamburger
R1 (config-line) # login
R1 (config-line) # exit
R1 (config) # service password-encryption
R1 (config) #
```

Configure a Banner

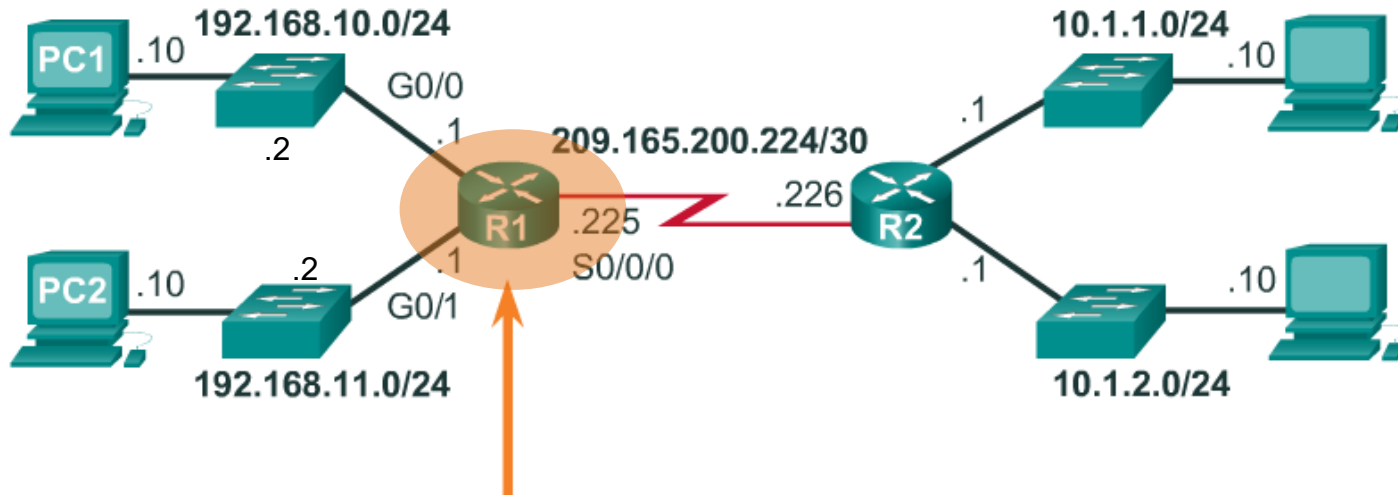

```
R1(config)# banner motd #  
Warning! Unauthorized access is prohibited!  
#
```

```
R1(config)#
```

Save the Configuration

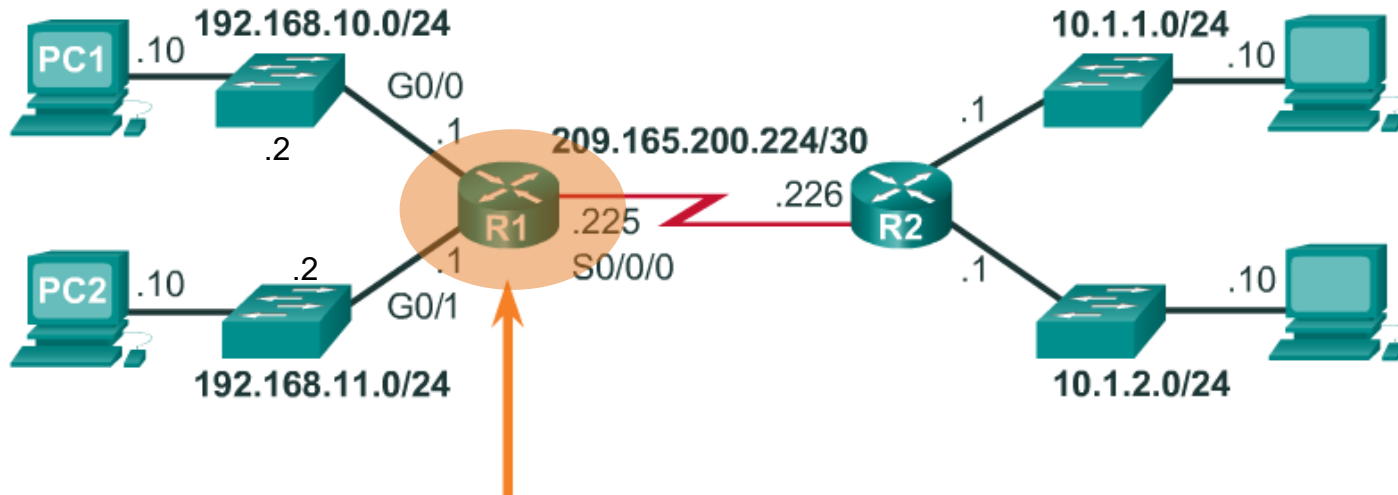

```
R1# copy running-config startup-config
Destination filename [startup-config]?
Building configuration...
[OK]
R1#
```

Configure Basic Settings on R2

```
Router# configure terminal
Enter configuration commands, one per line.  End with CNTL/Z.
Router(config)# hostname R2
R2(config)# enable secret hotdog
R2(config)# line console 0
R2(config-line)# password hamburger
R2(config-line)# login
R2(config-line)# exit
R2(config)# line vty 0 15
R2(config-line)# password hamburger
R2(config-line)# login
R2(config-line)# exit
R2(config)# service password-encryption
R2(config)# banner motd #
Warning! Unauthorized access prohibited!
#
R2(config)# end
R2# copy running-config startup-config
Destination filename [startup-config]?
Building configuration...
[OK]
R2#
```

Configure the Gi0/0 Interface

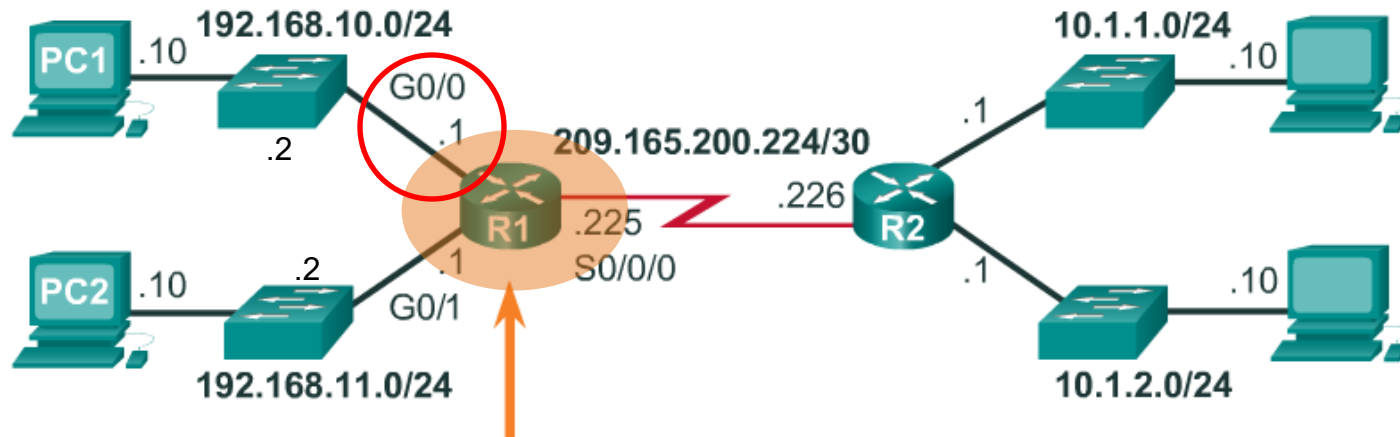

```
R1(config)# interface GigabitEthernet 0/0
R1(config-if)# description Link to LAN 1
R1(config-if)# ip address 192.168.10.1 255.255.255.0
R1(config-if)# no shutdown
R1(config-if)# exit
R1(config)#
*Jan 30 22:04:47.551: %LINK-3-UPDOWN: Interface
GigabitEthernet0/0, changed state to down
R1(config)#
*Jan 30 22:04:50.899: %LINK-3-UPDOWN: Interface
GigabitEthernet0/0, changed state to up
*Jan 30 22:04:51.899: %LINEPROTO-5-UPDOWN: Line protocol on
Interface GigabitEthernet0/0, changed state to up
R1(config)#
```

Configure the Gi0/1 Interface

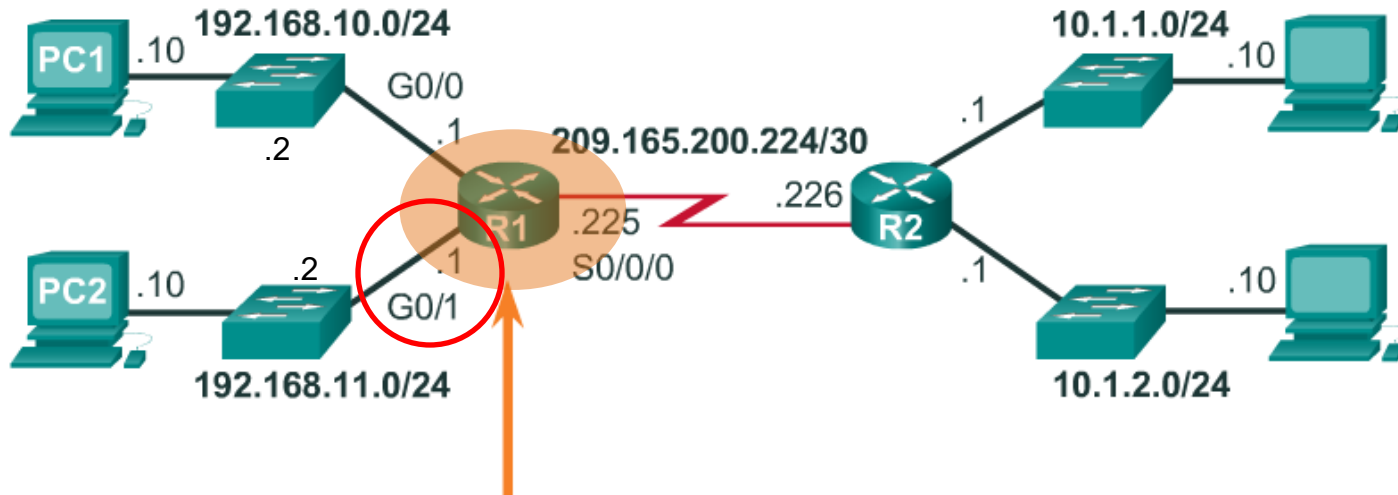

```
R1(config)# interface GigabitEthernet 0/1
R1(config-if)# description Link to LAN 2
R1(config-if)# ip address 192.168.11.1 255.255.255.0
R1(config-if)# no shutdown
R1(config-if)# exit
*Jan 30 22:06:02.543: %LINK-3-UPDOWN: Interface
GigabitEthernet0/1, changed state to down
R1(config)#
*Jan 30 22:06:05.899: %LINK-3-UPDOWN: Interface
GigabitEthernet0/1, changed state to up
*Jan 30 22:06:06.899: %LINEPROTO-5-UPDOWN: Line protocol on
Interface GigabitEthernet0/1, changed state to up
R1(config)#
```

Configure the S0/0/0 Interface

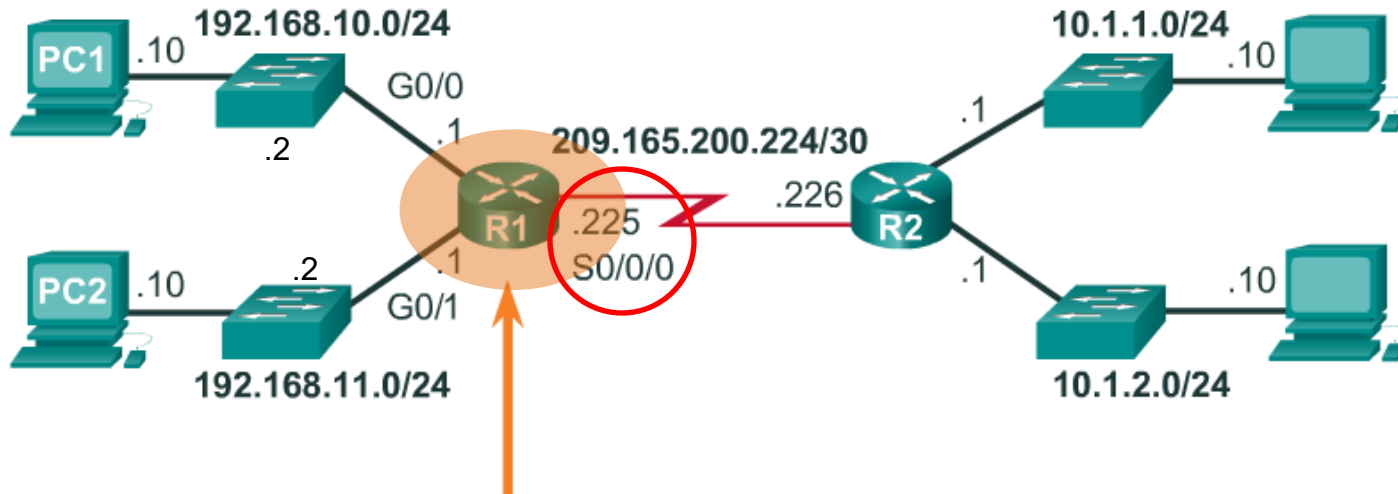

```
R1(config)# interface Serial 0/0/0
R1(config-if)# description Link to R2
R1(config-if)# ip address 209.165.200.225 255.255.255.252
R1(config-if)# clockrate 128000
R1(config-if)# no shutdown
R1(config-if)# exit
*Jan 30 23:01:17.323: %LINK-3-UPDOWN: Interface
Serial0/0/0, changed state to down
R1(config)#
```

Configure the R2 Interfaces

```
R2 (config) #interface GigabitEthernet 0/0
R2 (config-if) #description Link to LAN 3
R2 (config-if) #ip address 10.1.1.1 255.255.255.0
R2 (config-if) #no shutdown
R2 (config-if) #exit
*Jan 30 23:08:34.139: Output omitted
R2 (config) #interface GigabitEthernet 0/1
R2 (config-if) #description Link to LAN 4
R2 (config-if) #ip address 10.1.2.1 255.255.255.0
R2 (config-if) #no shutdown
R2 (config-if) #exit
*Jan 30 23:09:56.915: Output omitted
R2 (config) #interface Serial 0/0/0
R2 (config-if) #description Link to R1
R2 (config-if) #ip address 209.165.200.226 255.255.255.252
R2 (config-if) #no shutdown
R2 (config-if) #exit
*Jan 30 23:09:18.451: %LINK-3-UPDOWN: Interface Serial0/0/0, changed
state to up
*Jan 30 23:09:19.451: %LINEPROTO-5-UPDOWN: Line protocol on Interface
Serial0/0/0, changed state to up
R2 (config) #
```